

AerobTec Telemetry Converter

Futaba / FrSky Telemetry



Manufacturer:
AerobTec, s.r.o.
Ilkovičova 3
841 04 Bratislava

www.aerobtec.com
info@aerobtec.com

Obsah

1.Specifications.....	3
2.Introduction.....	3
3.Hardware description.....	3
Connectors of the Telemetry Converter.....	3
The power supply of the Telemetry Converter.....	4
4.The Telemetry Converter and the Altis Device.....	4
5.The Telemetry Converter and FrSky	4
The receiver.....	4
The transmitter.....	5
6.The Telemetry Converter and Futaba.....	6
The receiver.....	6
The transmitter.....	7
7.Warning.....	7
8.Correct disposal of this product.....	8
9.Notes.....	8
10.Revision History.....	8

1. Specifications

- > Dimensions: 18 x 11 x 5mm
- > Weight: 1.2g
- > Power supply range: 4 – 8.4V
- > Telemetry support for Futaba® S.Bus2 System, FrSky® Smart-Port(S.Port)

2. Introduction

The AerobTec Telemetry Converter is an extension of Altis Devices: Altis v4, Altis v4+, Altis Micro, Altis GPS. It enriches Altis Devices by new telemetric protocols of Futaba and FrSky.

The AerobTec Telemetry Converter selects only the essential from the wide range of information obtained during the flight of the aircraft. The essential information for Altis altimeters is the altitude and vario. The Altis GPS, however, works also with time, date and information associated with the coordinates.

3. Hardware description

Connectors of the Telemetry Converter

The Telemetry Converter has 2 connectors. They are shown in Fig. 1.

- COM – Molex connector for the connection with an Altis Device
- RX – Molex connector for the connection with telemetry equipped receivers

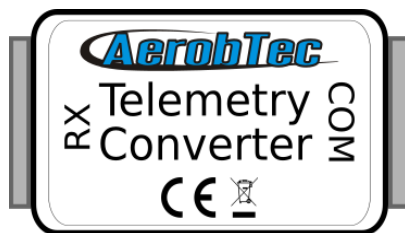

Fig. 1: The Connectors of the Telemetry Converter

Wire color	Signal
brown	Ground
red	Positive power supply
orange	Telemetry signal

Table 1: Colors of the connector wires

The power supply of the Telemetry Converter

The power supply of the Telemetry Converter must be done only from the Altis Device (connected to the COM connector of the Telemetry Converter) through the Molex/JR cable. The power supply of the receiver does not function when connected only through Telemetry Converter – the receiver needs a separate power supply. The signal polarity must be observed as shown in Table 1.

4. The Telemetry Converter and the Altis Device

Telemetry Converter is connected to the COM connector of the Altis Device with a pair of JR/Molex cables. In order to activate the Futaba/FrSky telemetry in the Altis Device through the Altis Flight Manager software as shown in the Fig. 2.

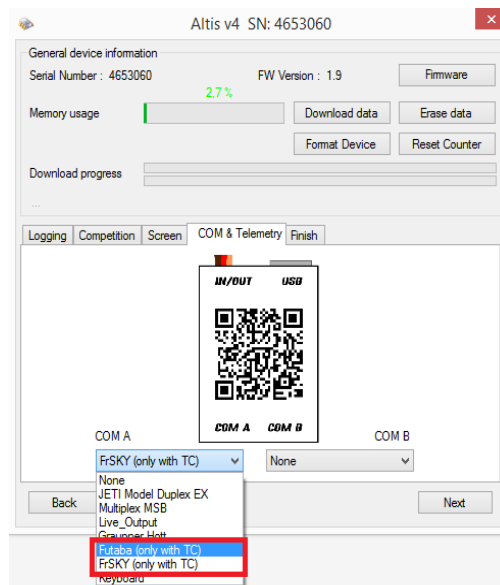

Fig. 2: Example setting in Altis Flight Manager (Altis v4 -> COM A)

5. The Telemetry Converter and FrSky

The Telemetry Converter communicates with the FrSky device through a FrSky Smart Port (S.Port) protocol. In the case of FrSky telemetry, only the receiver may be connected to the RX connector.

The receiver

First of all, it is necessary to find the appropriate connector on the receiver (the one with a Smart-Port marking). In order to connect the Telemetry Converter with the receiver, a JR / Molex cable must be used.

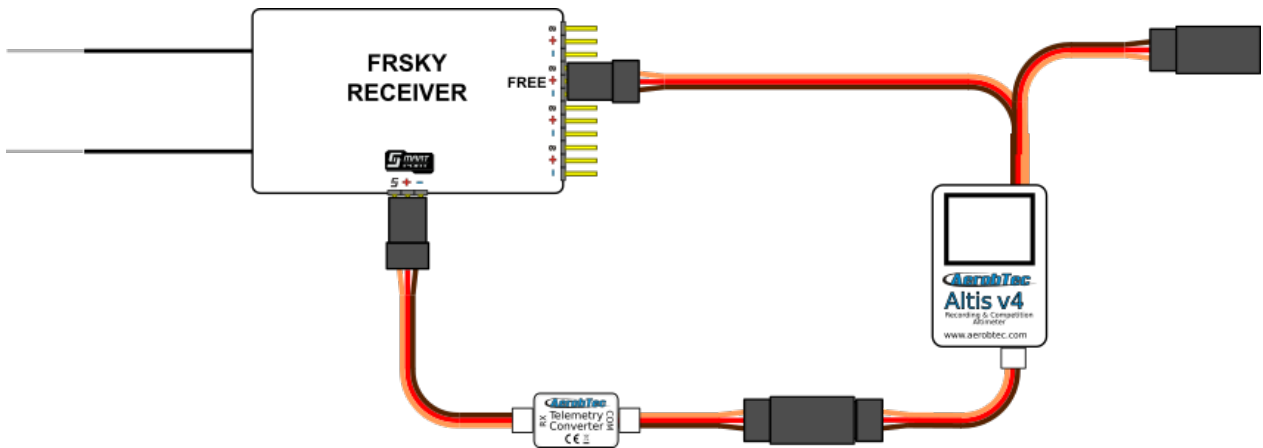

Fig. 3: The connection of the Telemetry Converter with FrSky

The transmitter

The telemetric information from the Altis Device are transformed via the Telemetry Converter and are displayed on the FrSky transmitter. In order to set the telemetric parameters, it is necessary to follow the user manual which can be downloaded here: <http://www.frsky-rc.com>

FrSky terms for individual telemetric parameters are listed in Table 2 (for altimeters) and in Table 3 (for GPS).

Parameter	FrSky term	Unit
Relative altitude*	Alt	[m]
Vario	VSpd	[m/s]
Temperature	T1	[°C]

Table 2: FrSky telemetric terms in altimeters

Parameter	FrSky term	Unit
Relative altitude*	Alt	[m]
Vario	VSpd	[m/s]
Temperature	T1	[°C]
Absolute altitude	GAlt	[m]
Heading	Hdg	[°]
Distance*	Dist	[m]
Speed	Spd	[km/h]

Table 3: FrSky telemetric terms in GPS

Depending on the model of the transmitter, the FrSky terms may vary. (Tested for X9D model).

*These parameters are relative, therefore their reference point must be set by restarting the transmitter or by resetting the telemetry on the transmitter.

6. The Telemetry Converter and Futaba

The Telemetry Converter communicates with the Futaba device through a Futaba S.BUS2 System protocol. In the case of Futaba telemetry, the receiver, as well as the transmitter, may be connected to the RX connector.

The receiver

First of all, it is necessary to find the appropriate connector on the receiver (the one with a S.BUS2 marking). In order to connect the Telemetry Converter with the receiver, a JR / Molex cable must be used.

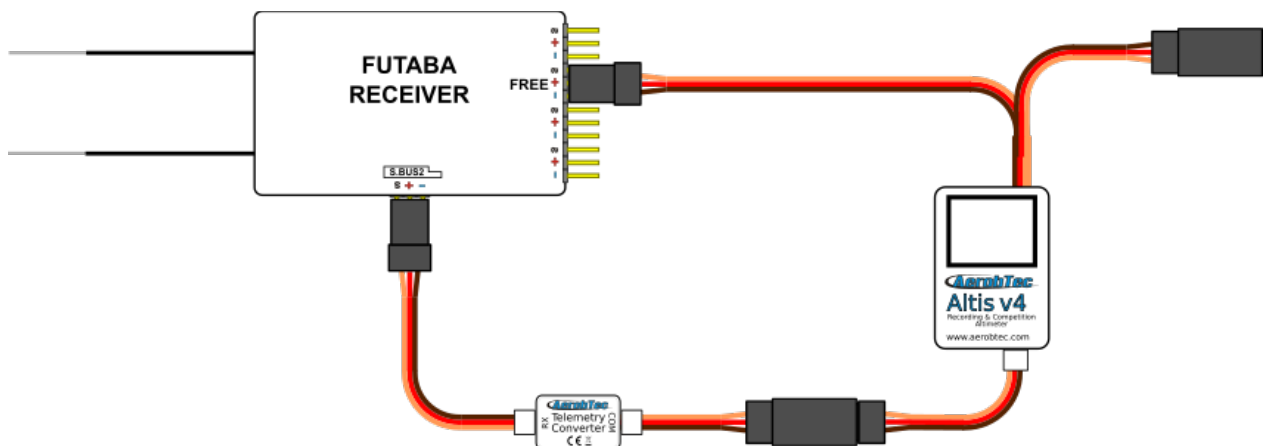

Fig. 4: Connection Telemetry Converter with Futaba receiver

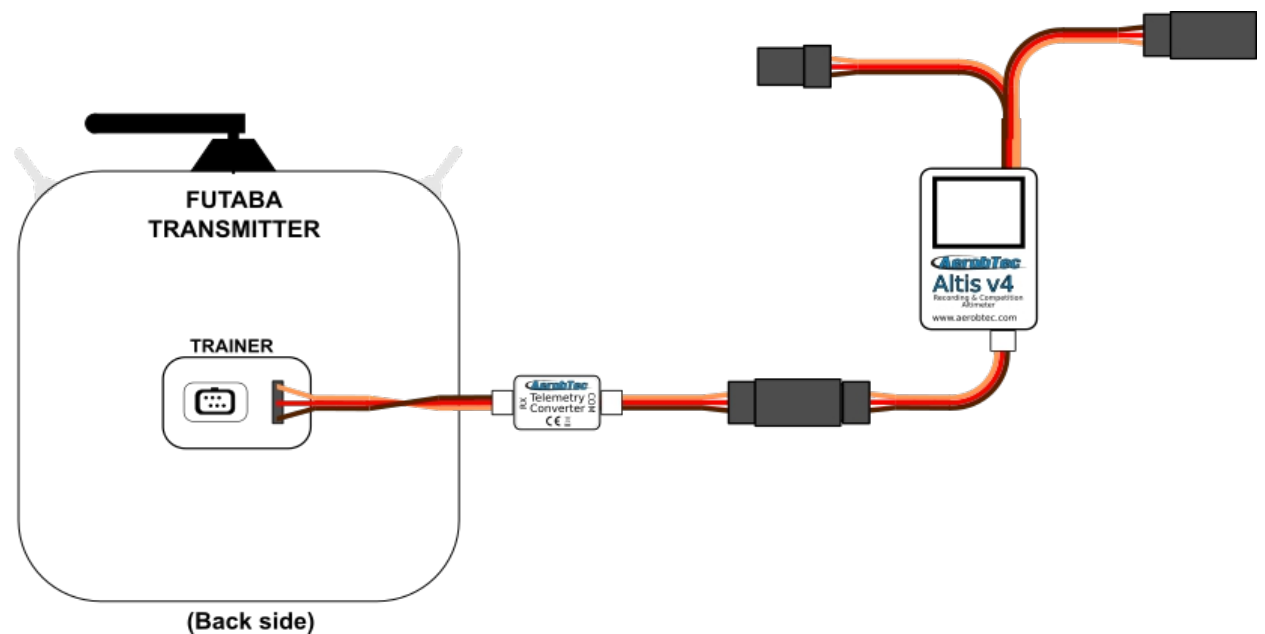

Fig. 5: Connection Telemetry Converter with Futaba transmitter

The transmitter

The Futaba transmitter is able to display telemetric data, but for this purpose it is, first of all, necessary to register a sensor. The registration of the sensor is done by connecting the transmitter directly to the Telemetry Converter (connect through the RX connector). In order to set the telemetric and sensoric parameters, it is necessary to follow the user manual can be downloaded here: <http://www.futabarc.com>

The Futaba sensor terms for Altis Device are shown in the table below:

Altis Device	Futaba sensor	Serial number
V4	Vario-1712	02129
V4+	Vario-1712	02129
Micro	Vario-1712	02129
GPS	GPS-1675	03280

Table 4: Futaba sensor terms for Altis Device

The specification of the telemetric information displayed on the transmitter are shown in Table 5 (for altimeters) and Table 6 (for GPS).

Parameter	Futaba term	Unit
Relative altitude*	ALTITUDE	[m]
Vario	VARIO	[m/s]

Table 5: Futaba telemetric terms in altimeters

Parameter	Futaba term	Unit
Distance*	DISTANCE	[m]
Speed	SPEED	[km/h]
Relative altitude*	ALTITUDE	[m]
Vario	VARIO	[m/s]

Table 6: Futaba telemetric terms in GPS

Depending on the model of the transmitter, the Futaba terms may vary. (Tested for T14SG model).

*These parameters are relative, therefore their reference point must be set by restarting the transmitter or by resetting the telemetry on the transmitter.

7. Warning

Do not touch the Telemetry Converter device to a metal surface, as this might lead to shorting of the power supply and RC system may fail.

Do not put the Telemetry Converter in water, fuel or other liquids!

Before flying with the Telemetry Converter always perform a range check!

8. Correct disposal of this product



This product should not be disposed with other household wastes at the end of its working life. To prevent possible harm to the environment or human health from uncontrolled waste disposal, please separate this from other types of wastes and recycle it responsibly to promote the sustainable reuse of material resources. Household Users should contact either the retailer where they purchased this product, or their local government of fice, for details of where and how they can take this item for environmentally safe recycling. Business users should contact their supplier and check the terms and conditions of the purchase contract. This product should not be mixed with other commercial wastes for disposal.

9. Notes

- > This manual is based on Altis Flight Manager version 4.0.0
- > Note – Telemetry Converter was developed using Atollic TrueSTUDIO®

10. Revision History

Rev. 1.0. (March 2015)

- Initial release