



Radio Controlled  
**Soaring Digest**

March 2017

Vol. 34, No. 3



**Front cover:** Sukhoi Su-27 Flanker built by Matt Jones from the Andy Conway PSS plans. Model is now owned and flown here by Bob Jennings. It is finished in the colours of the Ukrainian Air Force. The model is seen here soon after launch at the Bwlch, South Wales, May 2016. Photo by Phil Cooke, PSSA <<http://www.pssaonline.co.uk>> Canon EOS 7D, 1/1250 sec., f5.0, 100mm

- 4 Gordy's Travels**  
**Winter Blues and the "New" (to the USA) F3RES Class**  
Gordy Stahl investigates F3RES through interviews with experienced aeromodellers and provides data on several of the kits/ARFs available for contest work. Also see "Tips for F3RES Airframes" by Larry Jolly on page 18.
- 15 NASA/MIT Morphing Wing**  
By Beth Stackpole, *Digital Engineering*.
- 19 Kinetic Transonic DP**  
With a specially designed airfoil, this new DS 'ship looks like another record breaker. By Spencer Lisenby.
- 23 Three Books by Vittorio Pajno**  
"Sailplane Design," "Light Airplane and Glider Static and Dynamic Stability," and "Sailplane Design Example." Information courtesy of Paul E. Remde / Cumulus Soaring, Inc. <<https://www.cumulus-soaring.com>>.

- Airfoil System for Cruising Flight 26**  
Biologically inspired wing flow control uses a flexible extended trailing edge. From NASA *TechBriefs*.
- New 60" Dynamic Soaring Record 27**  
**On the 'Wing...**
- The Integrated Minimum Drag Solution 28**  
More about PRANDTL-D from NASA *TechBriefs*.
- Tom's Tips - Center between two holes 30**  
Tom Broeski explains the methods.
- Candidate for the slope - Archangel 1 31**  
One of the initial designs on the road to the A-12 / SR-71.
- Aer-O-Tec Takeo 32**  
A 3.6m sailplane or electric power airframe. Reasonable price and comes with its own aluminum travel case!

**Back cover:** Alexis Scott's Cirrus flying at The Bluff South Australia. The Cirrus is scratch built from a mould made from a heavily modified, shortened, etc., Rosenthal 1/3 Nimbus 2b. The wings are foam with hoop pine skins, tail surfaces are balsa skinned, and all are covered with automotive vinyl wrap. Nikon D200, ISO 200, 1/3200 sec., f5.6, 22mm

# R/C Soaring Digest

March 2017

Volume 34 Number 3

Managing Editors, Publishers  
Contributing Editor

Bill & Bunny (B<sup>2</sup>) Kuhlman  
Spencer Webster

Contact

bsquared@rcsoaringdigest.com  
<http://www.rcsoaringdigest.com>  
Yahoo! group: RCSoaringDigest

FaceBook: <https://www.facebook.com/RCSoaringDigest>

*R/C Soaring Digest (RCSD)* is a reader-written monthly publication for the R/C sailplane enthusiast and has been published since January 1984. It is dedicated to sharing technical and educational information. All material contributed must be original and not infringe upon the copyrights of others. It is the policy of *RCSD* to provide accurate information. Please let us know of any error that significantly affects the meaning of a story. Because we encourage new ideas, the content of each article is the opinion of the author and may not necessarily reflect those of *RCSD*. We encourage anyone who wishes to obtain additional information to contact the author.

---

Copyright © 2017 *R/C Soaring Digest*  
Published by B<sup>2</sup>Streamlines  
<http://www.b2streamlines.com>  
P.O. Box 975, Olalla WA 98359  
All rights reserved

---

*RC Soaring Digest* is published using Adobe InDesign CS6

## In the Air

This edition of *RC Soaring Digest* has turned out to be a real potpourri of materials from a wide variety of sources.

Our thanks to Gordy Stahl for contributing the extensive article detailing F3RES which starts on page 4 of this issue. Gordy devoted a lot of time and energy to interviews and data collection, and it definitely shows in the final product. Gordy's hope, and ours, is this information will further stimulate modellers to get excited about this new contest class.

Bill Scott of the Northern Ireland Association of Aeromodellers posted a link to Roger's Hobby Center in Saginaw, Michigan, devoted to understanding LiPo batteries. The page <<https://rogershobbycenter.com/lipoguide/>> is filled with information and includes a number of topics which may still be confusing to some. Everything is explained with simple terms and concepts and is easily understandable to those who may have concerns about switching from NiMH to LiPo power systems. This page is a long term project which is updated as relevant information is included.

And Mario Brandner, Salzburg Austria, sent in links to a 4-part video created at the 1990 Viking Race. Definitely worth a look!

Part 1 <<https://www.youtube.com/watch?v=UcEs7HkpRM0>>  
Part 2 <<https://www.youtube.com/watch?v=8X4LQDHL3mM>>  
Part 3 <[https://www.youtube.com/watch?v=VPs7qm2l\\_wY](https://www.youtube.com/watch?v=VPs7qm2l_wY)>  
Part 4 <<https://www.youtube.com/watch?v=RBfL9JflnEI>>

Time to build another sailplane!

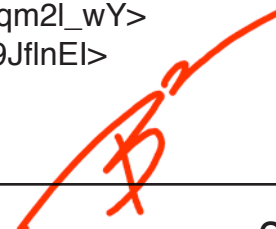

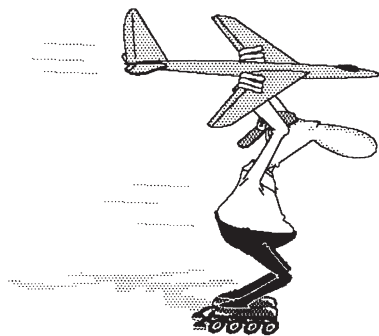

## Gordy's Travels

# Winter Blues and the "New" (to the USA) F3RES Class

Gordy Stahl, [GordySoar@aol.com](mailto:GordySoar@aol.com)

Winter blues is when the weather has driven most of us RC soaring guys to the point that we'll get excited about anything. It drives us to passionate arguments on RCSE and RC Groups. "Which sailplane is best," "Landing points should be abolished," "Dork landings aren't skillful," "Skegs on ALES planes will be the end of RC soaring," etc., etc... 😊

Then when the sun comes out, it's all forgotten.

I had heard about a popular class popping up in Europe involving 2 meter ships launched with high starts. Simple and cheap, but a lot of fun for the past couple of years. In fact it was that class that inspired the Miles 2m designed by Phillip Kolb some years back.

I kept the corner of my eye on it because our own club has had a very successful and fun contest series which endured in popularity also launched by matched

high starts. And I really enjoy flying it, too!

I noticed that there was a flurry of postings about the Euro Class called F3RES, previously known as F3B-RES. While it's not an official FAI competition, it follows that sort of task discipline.

Searching RC Groups I ran across "Glidermang" Greg McGill's handle. Turns out sort of by accident Greg gets the "Father of F3RES in the US" title because of his and his friend Jeff's focus on the models created overseas. Greg and Jeff's club has been flying a fun version of the class rules they call Hiss and Boink.

The Rules: "F3B-RES is a competitive class for radio-controlled gliders with a maximum of two (2) meter wingspan constructed predominantly of wood. Control is via elevator, rudder and spoiler. If used, spoiler(s) must be on the wing upper surface at least 5 cm ahead of

the trailing edge. The spoiler(s) can be controlled with either one or two servos. Launches are to be done with a hi-start."

F3RES Class Rules Link : <<https://www.rcgroups.com/forums/showatt.php?attachementid=9481781&d=1477856657>> / <<http://tinyurl.com/jqekkjy>>.

### **F3RES "Hiss and Boink" (or F3RES "Lite") Albuquerque-style**

Mostly it refers to a group evaluation of the contestants' landings. If the model slides into the points, the group "hisses," and if the nose hits the group yells "boink" and he's earned a zero landing.

Its all in fun, but the goal is to guide the pilots into avoiding landings that might damage the models and to get them to better control the energy of their models during the landing approach.

I asked Greg and Jeff to write a bit of a bio of themselves and their unique



*A typical hi-start Tuesday in Albuquerque.*



*PurRES and first Slite.*

relationship that began the quest to test just about every F3RES kit available.

From Greg:

I've been in airplanes all my life: my Dad used to take me to the flight line, and leave me in a SAC bomber to play all day. I earned a degree in aeronautical engineering, but can not design an airplane to save my life. However, I entered professional life as a flight test engineer, and that's my calling: figuring out if something works or not. My passion is soaring flight. F3K (Discuss

launched models) hooked me first. They were just too easy to take somewhere and fly, fly fly until my brains run out my nose. 😊 I never could justify a winch or some of the trappings that go with the fancier soaring models. As my strength and coordination disappear for tossing discuss launch birds, my interest is switching to F3RES aircraft.

How Jeff and I came to this:

I met Jeff flying F3K, and I believe I even timed for Jeff the day he first made a 4-minute flight in an F3K contest. Jeff

was injured in a serious accident which put him in a wheel chair but soon he was exploring ways to get back into the RC soaring game. As I remember it (and he maybe remembers it better, or more correctly), he asked me to build a simple glider for him for pay. I was uncomfortable taking money to build, so the deal became: he bought two models, and I built them both. He took one, and I took the other. At the time, I had just found the PuRES glider, and after the usual experience with the usual wood 2m's available from the past

(Gentle Ladies and so forth), I found the PuRES performance to be astounding. More F3RES-type models were becoming available, so Jeff suggested a comparison, and that became our goal, a fun project we could share building, flying and comparing models.

Creating a Comparison: One guy building means that assembling a fleet of different ships for comparison is a slow process. However, we now have numbers of PuRES, Slite and X-RES sailplanes, and we should be able to do something systematic this Spring. I have had matched pairs of F3K airplanes in the past, and I know we can systematically evaluate comparative sink rates and handling qualities.

The neat thing about these ships has been the enormous thought each designer has put into making each kit easy to assemble precisely. The kits we have examined have been very fine examples of CNC routing and laser cutting. Generally, fit and finish has been excellent. Wood has been exceptional, carbon and plastic parts are appropriate, and drawings and documentation (even in the original German language) is complete and detailed. Our feeling is that any builder can assemble a precision airplane that meets the intent of its designer.

For our club, the best level playing field for all participants has been the Hiss n Boink contest, which we have been conducting for over twenty years now. The neophyte gets to fly alongside the best, using equivalent equipment. The advent of the PuRES put the owners of the Gentle Ladies and Sagittas on notice, that there is a new game to be played, but anyone can still play it. Balsa is not just balsa any more, and 2-meters can be plenty big.

The designers of these airplanes have put together modern airfoils and equipment into a 2-meter package with low wetted area. The result is high speeds between thermals. At the same time, clever engineering and use of carbon tubes has driven weights to the vicinity of 14 ounces, ready-to-fly. The results are



*PurRES.*

airplanes that climb well, and run like stink. The Gentle Ladies, Gnomes and Risers simply can't keep up. It's fun for both Jeff and I (the most important part), we are sharing the adventure together.

One great thing is the precision that the kits are constructed. Most are laser cut and come with building aids, like slotted spacers used to hold the ribs in alignment and spaced for gluing, etc. Its not the old style of pinning over the plan on a building board, so the kits end up almost manufactured ARF perfect when done by a novice builder.

If you type in F3RES into the search bar on RC Groups, you'll find just about all of our builds threads and quite a few by others wringing out kits in front of your eyes.

My favorite is the PurRES and its latest version the Slite which the designer says stands for "Slightly better than the PurRES". But I'm a bit biased because it was our first model in the

process. What we have found is that every single model has been fantastic, in both build design and performance. On average you end up with a durable ship that weighs in between 14oz and 19ozs yet doesn't care much about the wind.

The performance of the PuRES and Slite had put the local boys on notice (who had been flying the usual old USA 2m kit designs), and we are seeing more and more F3RES airplanes here in Albuquerque.

There are eight Slites and PuRES kits on their way to locals at this time, due by the end of January.

(Here's a link to one of Gregs awesome build logs on the Slite in RC Groups: <<https://www.rcgroups.com/forums/showthread.php?2630580-SLITE-2-meter-RES-Sailplane>> / <<http://tinyurl.com/hhkkwrz>>.)

We have multiple examples of the X-RES and Pica-RES building, and four of the RESoholics. In my garage, waiting for me, are two RESolutions, three Baba Jaga Cs, and two MAD-RES kits. Enthusiasm for the class organized a club group buy of the official F3RES hi-starts – Zeller is the supplier and as I type Zeller is sending 10 official F3RES hi-start kits.

I guess it's a good time to announce that our club will be holding the first F3RES event in the SouthWest - Nov 4-5, 2017.



*The X-RES.*

More details can be found on RC Groups (Events).

And speaking of the PuRES and the Slite (which stands for slightly improved over the PuRES)...

Here is some F3RES history from their designer and kit supplier Josef Gergetz <<http://www.seta-tech.de/>>.

Josef wrote:

“Just a note of interest – all the members of our RES competition team have also high class F3J / F3B ships, but when we meet at the airfield we take out our RES

planes and have so much fun together!

“The performance of a well designed and lightweight plane was and is really surprising so I think it is not a wonder that F3RES gets more and more interested pilots!

“F3RES was considered as a beginner class, but it is interesting that F3J competition pilots and “retired” F3B pilots are now participating. It took Germany and Austria by storm and the excitement spread over to our neighboring countries.”

I had “met” Josef via email about his kits a few weeks back, clearly he was an RC sailplane addict same as me, so we had a lot of common ground. When the idea for an article about Greg and Jeff popped into my head, Josef was likely the go-to guy for some history on the class development overseas. I had sent Josef a few questions and he was quick to reply with the following details:

F3RES started in Turkey. RC modelling generally and especially rc sailplane flying was pushed a lot by the financially strong investor Mustafa Koç.

Mustafa has since passed, he was a true patron of RC soaring, his beginnings in the hobby started in college in NY, his roommate the amazing RC enthusiast Skip Schow (also passed) would build RC sailplanes in their room! I am so lucky to have flown and know both.)

Mustafa was such an enthusiast, he even engaged a well known world class F3J pilot from Germany to support him with his ideas: Phillip Kolb.

2008/2009 the 2M woody class was already quite popular there and they started with the first competitions. (Gordy note: Larry Jolly was at some of those contests and involved as an inspiration for the class and the Miles.)

Phillip Kolb’s “Miles” is one of the famous models from that time. Of course Phillip reported about the Turkish activities to Germany, and on our platform “[rc-network.de](http://rc-network.de)” the first mentionable discussion about F3RES started 2010/2011.

2012 there happened the first competitions in Germany. For instance I organized the 2nd RES competition in Germany: <<http://www.rc-network.de/forum/content.php/201-2.-Deutscher-RES-Wettbewerb-in-Dachau>> / <<http://tinyurl.com/zqot3ns>>. 13 pilots from all over Germany met here. Some of them were driving abt. 600 km to participate.

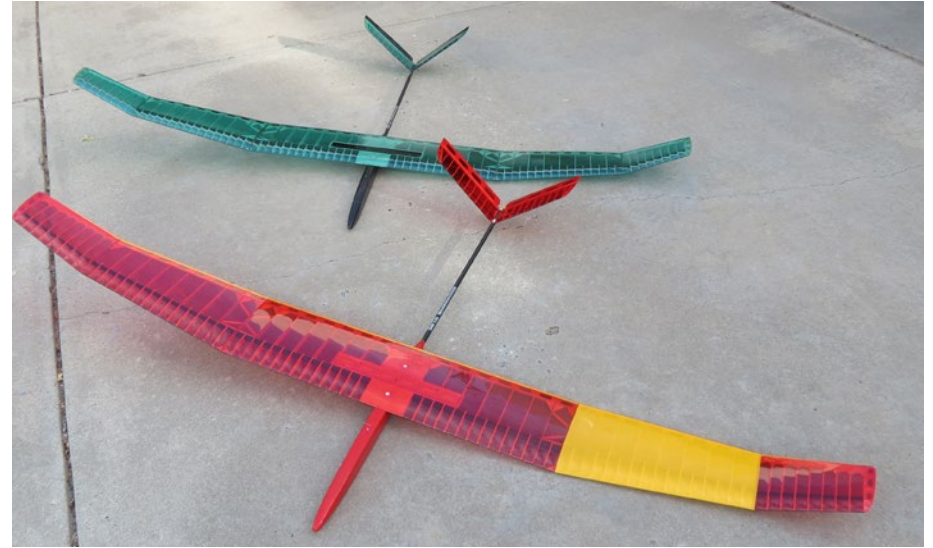

*My PurRES duo.*

From that day on, more and more commercially available and competitive sailplane kits appeared on the market, and the number of competition pilots exploded!

Due to the size of our airfield, I now have to restrict the amount of pilots to 35. Without restriction 50 would be there for sure.

Here is a list of F3RES Euro Champ competitions:

2014 in Hirzenhain

2015 in Wetzlar

2016 in Dillingen

We had the Open German F3RES Championships.

Number of pilots varied from 60 to 70.

In parallel we have the “German RES Tour,” which combines all of the German contests (abt, 15-20 local contests are expected for 2017).

Last year more than 100 pilots were listed in the RES tour!



We have also a workgroup for F3RES in Germany which consists of 10 active pilots and competition organizers. Main tasks for the workgroup are discussing and adapting the rules (if necessary), and keeping track that the class stays simple in general.

I hope this helps all understand the strength, excitement and depth of this new event class of RC sailplanes.

— Josef

The Model Kits at this point :

-----

PuRES:

Josef Gergetz, a boutique builder. Pod-and-boom fuselage with ribbed wing on carbon tubes. Materials are first-rate, balsa is CNC-routed. Fit and finish is exceptional. Controls are push rod (supplied). Parts count is rated as “High.” Full size plans included, instructions can be downloaded in English. Build thread on RCGroups.com.

Options: Spoiler servo (ribs are machined to fit servo available from Josef); choice of flat or built-up and profiled V-tail.

Build experience: Pleasant, about 30 hours.

Flight experience: Excellent performance, very popular in Albuquerque.

Source: SETA-TECH.de

Cost: €139

Parts fabrication: CNC-routed from sheet. Commercial carbon tubes for spars and booms.

Materials: Excellent quality throughout in every kit we’ve seen.

Controls: V-tail and single spoiler, push rods included.

Plans: Full-scale, German, with English-language instructions available. Build thread on RCGroups.

Options: Inexpensive spoiler servo, choice of sheet or built-up tail (at increased cost).

Build experience: Pleasant, but parts count is high. Self-jigging wing ribs and supplied jigs help a lot. No pin board required, only a flat surface. Very straight-forward for a builder with any experience in wood.

Flight experience: Excellent, very impressive in both light and windy conditions. We have flown in 15mph winds with 40g of ballast.

-----

Slite:

By Josef Gergetz, a boutique builder. Designed to be “slightly” better than the PuRES. Pod-and-boom fuselage with ribbed wing on carbon tubes. Materials are first rate, balsa is CNC-routed. Fit and finish is exceptional. Controls are pull-spring (supplied). Parts count is rated as “Very High.” Plans are included, but not full size, neither are they needed – instead, comprehensive jigs are supplied with the kit. No English instructions, but English build notes can be downloaded to supplement the plans. Build thread on RCgroups.

Options: Spoiler servo (as in PuRES); choice of built-up V-Tail with profile, or built-up, flat conventional tail.

Build experience: Pleasant, but parts count is very high – takes about 40 hours.

Flight experience: Excellent performance, not as responsive in roll/yaw as PuRES

Source: SETA-TECH.de

Cost: €169

Parts fabrication: CNC-routed from sheet. Commercial carbon tubes for spars and booms.

Materials: Excellent quality throughout in every kit we’ve seen.

Controls: V-tail or conventional tail, central spoiler, pull-spring included.

Plans: Less than full-scale, German only, but English build notes available. Build thread on RCGroups.

Options: Inexpensive spoiler servo, choice of V-tail or conventional tail (both built-up).

Build experience: Pleasant, but very high parts count, maybe 25% more than PuRES. Instead of full-scale plans, a comprehensive jig set is included. No pin board required, only a flat surface. High parts count may pose a problem for those without patience.

Flight experience: It grows on you. Lighter than PuRES, also less draggy (although the PuRES is not very draggy at all).

-----

#### X-RES:

Sources are either Zeller Modellbau or Hyperflight.co.uk. Entirely wood construction. Box fuselage with partially sheeted wing. Materials are very good, balsa is CNC-routed. Controls are push rod (supplied), and horizontal tail is all-flying. Parts count is rated as "Average." Full-size plans included, and necessary for the build. Build thread on RCGroups, but no English instructions.

Options: None.

Build experience: Pleasant, no more than 30 hours.

Flight experience: Surprising climb performance in light conditions.

Source: Hyperflight.co.uk, or Hoelleinshop.com

Cost: €145

Parts fabrication: CNC-routed from sheet, some strip wood included.

Materials: Excellent, especially the sheet.

Controls: Conventional tail, with all-flying horizontal stabilizer. Dual spoilers.



*AndREaS*

Plans: Full-scale, German only, but pictures make it easy. Build thread on RCGroups.

Options: None.

Build experience: Very pleasant. Moderate parts count makes for a relatively quick build. Leading edge templates help shape airfoil. A pin board is necessary for the wings and tail surfaces. Some CNC-routed parts were somewhat fuzzy, but in the end, it didn't matter.

Flight experience: Surprising, mostly due to the very low flying weight obtained (usually less than 400g).

This airplane seems to always climb out.

## AndREaS:

Sources are either Zeller Modellbau or Hyperflight.co.uk. All-wood construction. Box fuselage with partially sheeted wing. Materials are good, wood is laser cut. Controls are push rod (supplied). Unique wing rod arrangement that allows easy ballasting for windy conditions. No English instructions, but plans and pictures from German instructions allow straight forward build. Build thread on RCGroups.

Options: None.

Build experience: Our kits were disappointing, but other reviews are very good. Trust the other reviews.

Flight experience: Too limited for evaluation.

Source: Hoelleinshop.com or Hyperflight.co.uk

Cost: €135

Parts fabrication: Laser cut from sheet, some strip wood.

Materials: Excellent quality.

Controls: Conventional tail, dual spoilers.

Plans: Full-scale, German only, but with excellent pictures. Build thread on RCGroups.

Options: None.

Build experience: Our kits exhibited problems with laser cutting, but other reviews are all positive. A pin board is necessary. An easy mod is to discard the steel wing joiner, and substitute a 5mm diameter carbon rod.

Flight experience: Limited at this point. The relatively heavy weight makes control response somewhat sluggish, but it thermals fine.

-----



*RESoholic*

## RESoholic:

Source is ar-fugmodelle.at. Unique, open-design box fuselage with partially sheeted wing. Wing has carbon spar caps, and unique planform. Materials are excellent, wood is laser cut. Controls are push rod (supplied). No English instructions, but plans (full-size) and pictures in German instructions allow straight forward construction, after some study and thought. High parts count. Build thread being developed on RCGroups. Unique design features may discourage some builders.

Options: None.

Build experience: incomplete as of this writing, but progressing smoothly.

Flight experience: none, yet (thread on RCGroups.)

Options: None.

Cost: €128

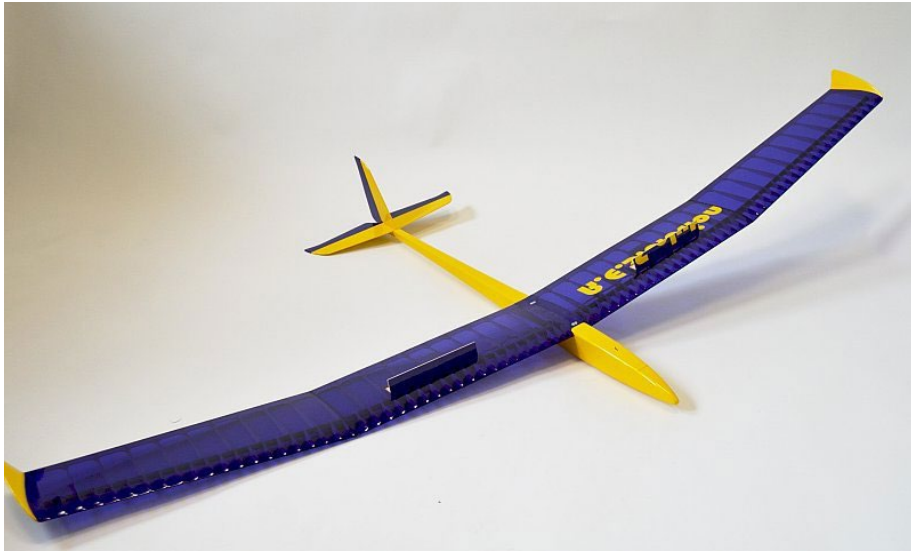

### RES-olution

Parts fabrication: Laser cut from sheet. Carbon strips for spar caps.

Materials: Excellent quality throughout in every kit we've seen.

Controls: V-tail with dual spoilers, push rods included.

Plans: Full-scale, German only. Excellent pictures on German instruction document. Build thread on RCGroups.

Options: None.

Build experience: pleasant, but non-traditional. No pin board required, only a flat surface.

Wing structure unlike any we have encountered before, but after study, easy to carry out.

Flight experience: None yet.

-----

### RES-olution:

Source is Hoelleinshop.com. Most traditional kit encountered so far. Box fuselage with ribbed wing, ribs on carbon spar. Conventional tail. Materials are excellent, wood is mostly laser cut with select parts CNC-routed. Unique picture instructions. Color-coded plans with many call-outs and notes.

Options: Instructions and parts included for power installation.

Build experience: None yet.

Flight experience: None yet.

Cost: €115

Parts fabrication: Laser cut from sheet. Commercial carbon tubes for spars.

Materials: Superb quality.

Controls: Conventional tail, dual spoiler, push rods included.

Plans: Full-scale, German only, color-coded. Picture-only instructions, like an IKEA product. Build thread planned for RCGroups.

Options: None.

Build experience: Not yet built, but this is the most traditional woody sailplane design we have seen. We anticipate an easy build, due to the superb quality of the sheet and laser cutting.

Flight experience: None yet.

-----

### MAD-RES:

Source is Fraundorfer.de. Unique, CNC-routed solid balsa wing blanks, with carbon spar caps. Pod and boom fuselage. Minimal parts count. Wood and materials appear of excellent quality. No English instructions, but simple manual (and extremely low parts count) should make for easy construction.

Parts fabrication: CNC-routed from sheet and solid balsa. Commercial carbon tube for boom.

Cost: €130



*MAD-RES*

Parts fabrication: CNC-routed from sheet and solid balsa.  
Commercial carbon tube for boom.

Materials: Excellent quality. Lowest advertised fly weight of roughly 300g.

Controls: Conventional tail, central spoiler, pull-spring included.

Plans: Not included, not needed. Wings are machined from solid balsa, with grooves for carbon spar caps. Build thread on RCGroups planned.

Options: None

-----  
RESi

Source: [modellbau-thiele.de](http://modellbau-thiele.de)

Cost: €250

Parts fabrication: ARF, built-up from wood and carbon tube in accordance with F3RES rules.



*RESi*

Materials: Excellent quality throughout in every kit we've seen.

Controls: Unique, all-flying V-tail with central spoiler. Push rods included

Plans: Not necessary - ARF. Build thread on RCGroups.

Options: A variety of color schemes.

Build experience: Pleasant, except for ill-fitting wing joiner rods, which must be laboriously sanded. Otherwise, assembly time would be on the order of six hours or less.

Flight experience: Pleasant in light winds. Very responsive to controls.

-----  
PicaRES:

Source: [modelbauchaos.de](http://modelbauchaos.de)

Cost: €139



*PicaRES*

Parts fabrication: CNC-routed from sheet.

Materials: Excellent quality throughout in every kit we've seen.

Controls: V-tail or conventional tail, central spoiler, push rods included.

Plans: Full-scale, German only. Build thread on RCGroups planned.

Options: V-tail or conventional tail (both built-up). Option to include power.

Build experience: None yet, but appears straight-forward.

Flight experience: None yet.

A really nice F3RES Resource page in RC Groups put together by Jon "Slowmatch" and includes just about everything related to the suppliers of F3RES kits, high starts etc.

<<https://www.rcgroups.com/forums/showthread.php?2696827-F3-RES-Resources>> / <<http://tinyurl.com/zzo5psy>>

I want to thank Greg for being Jeff's RC sailplane friend and Jeff for taking so much interest in the class. To both for agreeing to sharing their friendship in the hobby for this article.

To Josef for his historical information and to all the contributors on RC Groups (like Jon) so that we have something to do while its too cold to build or fly our RC sailplanes!

The reality of this class at the moment is at best a slow start in the USA this season as it take quite a bit of time to get the kits, assemble them as well as the high starts, landing tapes etc.

Larry Jolly (LSFV, ELSV#1 and LSF President) has announced that there will be an exhibition F3RES contest at the AMA Nationals this year. (See Larry's notes on F3RES on page 18 of this issue.)

I know that the Florida Soaring Society, the DARTs club of Dayton Ohio and others have put the pedal-to-the-metal in order to be ready to fly F3RES events this coming season.

I'm not sure that DP, or JW have sold off their big F3J ships to focus on F3RES but likely they will be part of the fun. You?

Hope you enjoyed this trip in to the new world of F3RES.

Got comments or questions? Contact me at <[GordySoar@aol.com](mailto:GordySoar@aol.com)>

See you on my next travels!



# NASA/MIT Morphing Wing

Beth Stackpole, Digital Engineering

<http://www.digitaleng.news/de/morphing-wing-design-lays-groundwork-for-soft-robotics/>

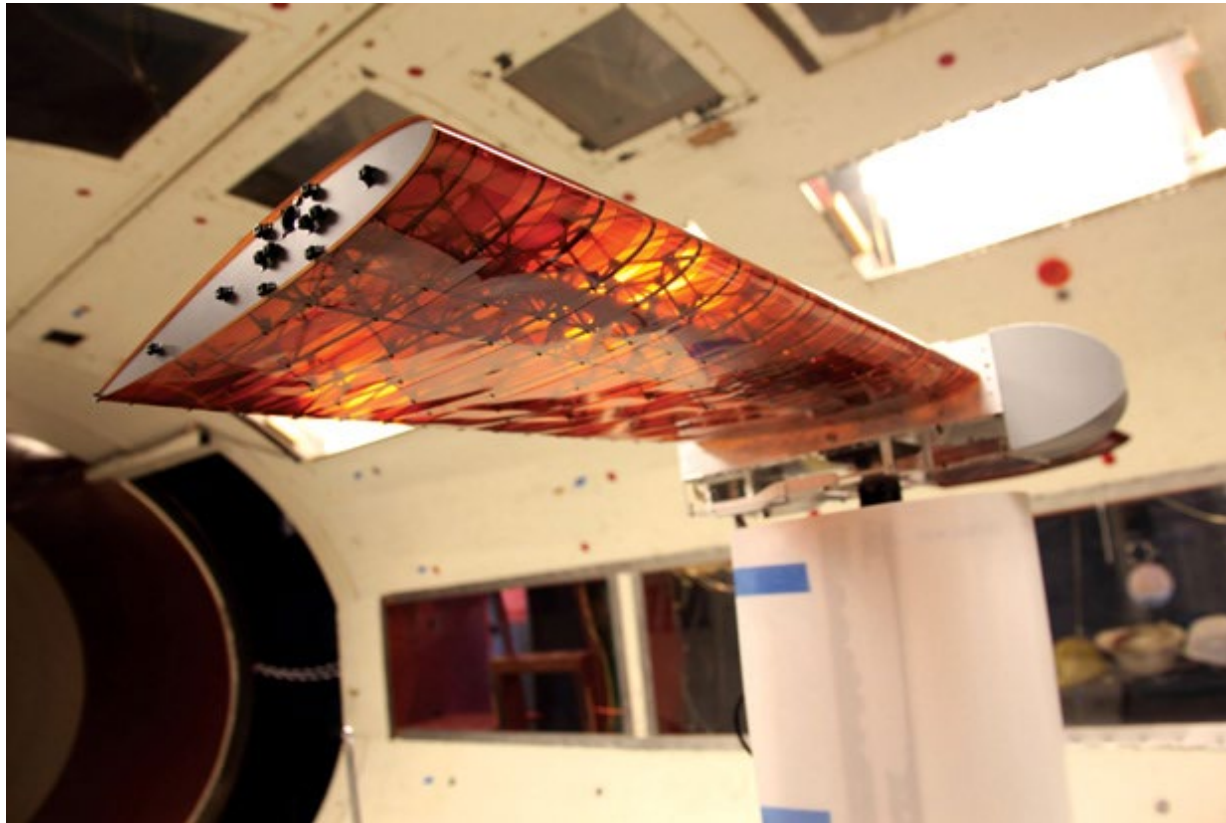

*With the MIT team's approach, the whole shape of the wing can be changed and twisted uniformly along its length by activating two small motors that apply a twisting pressure to each wingtip.*

*Image courtesy of Kenneth Cheung/NASA.*

Increased agility, enhanced aerodynamics and improved fuel efficiency are the central tenets of aerospace design.

A joint research project between NASA and MIT hits all those notes in addition to laying the groundwork for advancements in the emerging area of soft robotics.

Engineers at NASA and MIT's Center for Bits and Atoms (CBA) combined new digital materials concepts with a highly advanced robotic assembly method to create a new, "bendable" wing architecture that optimizes lift and roll.

The benefits of such an approach applied to an aerospace application like wing design, researchers say, is to increase aerodynamics and thus improve fuel efficiency and reduce greenhouse gas emissions.

Yet beyond its potential impact for aerospace applications, the research initiative is fueling innovations in the nascent field of soft robotics, the practice of applying soft materials like

silicone and plastic to create robotic structures that are more biologically accurate and capable of changing shape to ensure safer, highly sensitive interaction.

Soft robotics reached a milestone this summer when Harvard's Wyss Institute for Biologically Inspired Engineering unveiled the Octobot, the first robot to contain no plastic or metal parts while also employing pneumatics and chemistry, not electronics, to achieve autonomous operation. (Editor's Note: Read more at "Beyond Organic Shapes," <<http://www.digitalleng.news/de/beyond-organic-shapes/>>.)

Unlike the Octobot and other soft robotics efforts that rely on the use of elastomeric materials like rubber and manufacturing methods such as casting or 3D printing, MIT/NASA's digital materials concept stakes claim to a more scalable approach, making it better suited for the construction of large-scale objects like aircraft wings or wind turbine blades, according to Ben Jennett, a graduate student at MIT and a key contributor to the project.

The MIT/NASA research effort is based on the concept of assembling any number of tiny, lightweight pieces into a structure—in this case, an aircraft wing—with each building block or component precisely tuned for flexibility and movement (hence the digital materials concept), he explains.

The result, Jennett says, is the ability to combine both hard and soft characteristics into a single lattice geometry structure while achieving far greater scalability than what has been accomplished with many of the early soft robotics research projects.

"Our contribution to soft robotics is the ability to achieve the materials properties of elastomeric materials at ultra light density with scalability and the ability to use heterogeneous materials," Jennett says. "We're hoping that those in the soft

robotics field will recognize our approach as a way to build compliant robots."

## LEGO-Like Building Blocks

There are two primary pieces to the MIT/NASA research: The modular system of tiny, lightweight LEGO-like building blocks that comprise the wing structure and an advanced manufacturing technique that calls for a team of specialized and synchronized robots to assemble the subunits into a whole.

The building blocks are essentially an ultralight cellular solid created by stitching together modular 2D elements at a voxel level and fine-tuning their performance characteristics and the geometry of their assembly, Jennett explains. This digital materials approach gives design teams the flexibility to achieve high levels of stiffness and strengths in some areas of a particular structure while also incorporating compliant and energy-absorbing characteristics in others.

In addition, the design approach, which is supported by a unique robot assembly ecosystem, is more scalable than creating lightweight lattice structures with additive manufacturing (AM) techniques that rely on a continuous process of extrusion, he says.

"By using a discrete set of parts, we can tune local properties to determine global properties—that's the innovation," Jennett says. "When you think of a material as something that's digital, you have bit-level control over the properties of whatever you are building."

The digital materials concept also advances the scalability of the kinds of structures you can produce with soft robotics characteristics and ultra lightweight materials. With AM production techniques, design engineers are limited by the size of a printer's build platform, among other factors, and the inability to make use of heterogeneous materials to fully optimize designs.



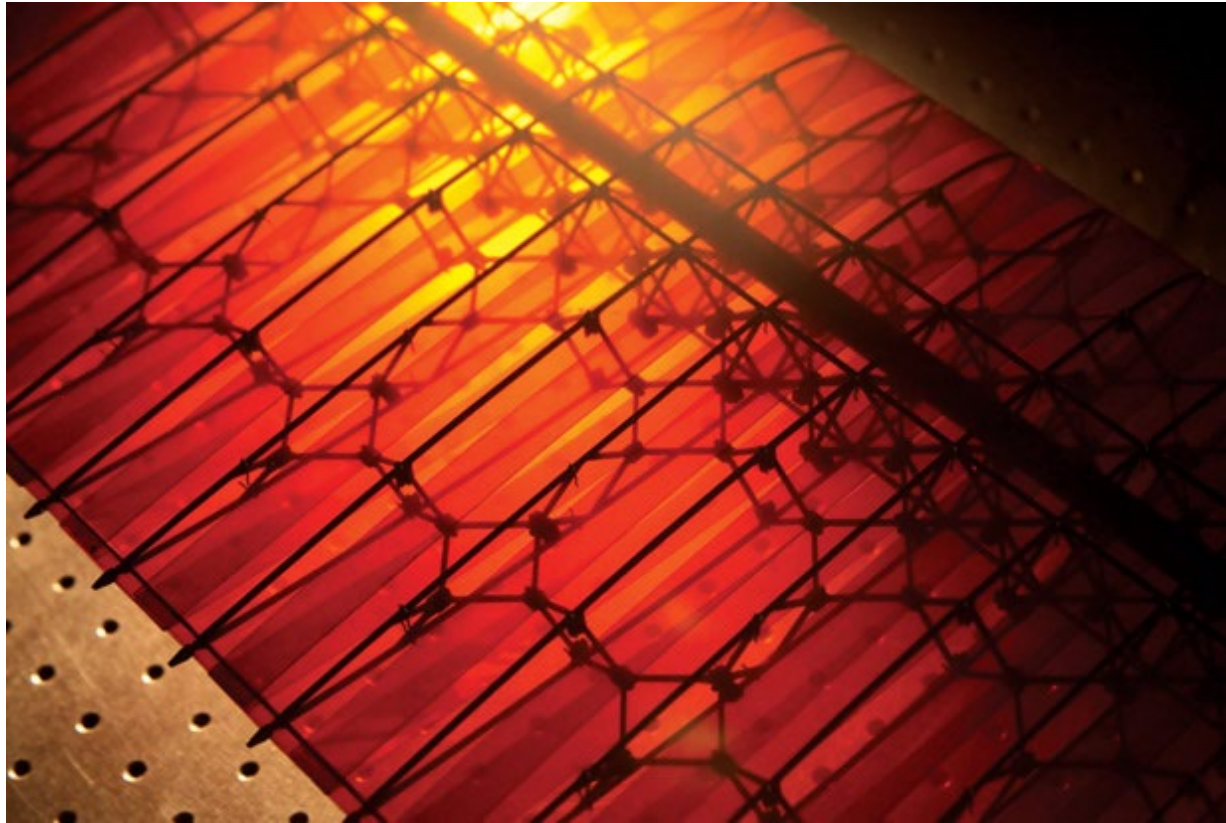

*The basic principle behind the new concept is the use of an array of tiny, lightweight structural pieces, referred to as “digital materials,” that can be assembled into a virtually infinite variety of shapes.*

*Image courtesy of Kenneth Cheung/NASA.*

With the MIT/NASA developed technique, one cellular building block could be carbon fiber and another elastic, and an engineer could combine them in ways that make the most sense for specific design objectives.

“Think of it as different LEGO bricks of different colors, but in this case, it’s different materials properties,” Jennett explains. “Our approach brings micro-level control to a macro scale, which can be applied to large-scale designs like airplane wings or wind turbine blades.”

This approach to design and manufacturing large-scale systems like airplane wings is also well suited for on-going maintenance and design work.

The LEGO-like parts are reusable, thus can be put together with various fastening techniques in different ways while also disassembled fairly easily for repairs. Contrast this with AM, which is a continuous process of extruding plastic or depositing metals, which is a hard thing to undo, Jennett says.

“When there’s a structural defect or error on a giant fuselage blade made by laying down composite tape, the whole thing has to be scrapped, which compromises the integrity of the monolithic element,” he explains. “With our approach, if one part is damaged, it can be easily replaced.”

## Robotics at Work

MIT put its digital materials concepts to the test with the NASA wing project. The goal was to create a wing design that would allow for twisting in a precise way that eliminates the need for separate structural pieces (like those found in conventional wing design) and that also delivers a smooth, aerodynamic surface.

To that end, the researchers created a skin to house the LEGO-like brick components and optimize the structure’s performance.

This part of the design takes its cue from nature — bird feathers or fish scales, to be exact — by layering strips of flexible materials that move across each other as the wing flexes, but that still retain a smooth exterior surface, according to researchers.

The soft robotic wing structure also supports a level of drag reduction that isn't possible with the rigid model, the researchers found.

Based on early wind tunnel tests, researchers found that the cellular solid wing design proved to match the aerodynamic properties of a conventional, rigid wing model at about one-tenth the weight while also exhibiting the potential to increase lift, Jennett reports.

Following the initial wind tunnel exploration, the team further tested the concepts by creating a flyable unpiloted aircraft, which included the wing structure along with a motor, at a California airfield and achieved promising results.

Future plans call for building an entire aircraft—wing, tail and fuselage—with digital materials, he added.

While the initial bendable wing was hand assembled, future digital materials efforts will involve the new robotic fabrication process that deploys a series of small robots to assemble the structure and actually do so in the operating environment.

This would lend itself to the production of large-scale wind turbine blades, Jennett says, which could be assembled at the point of operation without having to incur the expense of transportation and logistics.

“In order for digital materials to actually materialize as the transformative material they should be, it does require automation,” he says.



## TIPS FOR F3RES AIRFRAMES

Larry Jolly, ljolly@aol.com

It is important...

- To keep things where they need to be, the wood fuselage needs to be large enough in cross section so that it is not constantly needing repair.
- The wing should bolt on leaving space for ballast under it.
- The canopy allows for radio access and allows a pleasant styling.
- Having flown the event in Turkey, you should have two styles of glider.
  - If it is lively and blowing a higher aspect ratio similar to the Miles wing is helpful.
  - If it is dead a lower aspect ratio will give a better launch and better hang.
- The PK sections offer a good starting point.
- V-tails keep it simple and keep the horizontal off the ground.
  - Don't make them too small.
  - Start with 3/16" balsa and sand its thickness to 1/8" at the tip.



# Kinetic Transonic DP

Spencer Lisenby, sl914 on RCGroups

<https://www.rcgroups.com/forums/showthread.php?2819794-Kinetic-Transonic-DP>



Introducing the all new Kinetic Transonic DP! This plane was designed and built for all-out speed while still maintaining a mild mannered easy to fly behavior at frontside speeds. Our goal was to achieve the highest speed possible without resorting to swept wings. As usual, Dirk Pflug provided the airfoils and Thomas Pils provided a huge amount of design work as well as machining the fuselage molds. Jarda did an excellent job making the wing and stab molds in CZ and shipped them to me here in the US.

Dirk Pflug designed a suite of airfoils which were designed to delay the shock formation as long as possible and minimize the drag divergence up to 580mph. Dirk was also able to get help from Stuttgart University to optimize the wing using MSES. Our hope is that this transonic tailoring will allow the model to maintain a high wind-speed multiple well into the 500+mph range where other models performance drops off more rapidly. Although the airfoils were designed for transonic mach numbers, their performance remains surprisingly good at lower speeds. The 22:1 aspect ratio should also help boost the low speed performance where the airfoils are not in their prime.

The 130" wing on this first prototype is (1) piece for simplicity and the ultimate in strength / stiffness. Production wings will be (3) pieces to facilitate shipping and transportation to the hill. This first model weighs roughly 240oz (6.8kg). That puts the wing loading at approx 45oz/sf (137g/dm<sup>2</sup>). Ideal ultimate flying weight will likely be closer to 300oz (8.5kg).

With everything about this model being new, I was really eager to get it flying but also wanted to make sure we had enough wind for a successful maiden. The weather this winter has been very wet and not all that windy. Once I finished the plane and had it RTF, I decided to quit shaving until I was able to fly it. For over 2 weeks, the wind refused to cooperate. As a result, the model made two trips to the hill prior to making its maiden this past Saturday at Weldon (Southern California) and my beard grew long. 🚂

On the way to Weldon, we were greeted by 8" of fresh snow on the ground and icy roads as we came through Walker Pass. When we got to Weldon, the whole hill was blanketed in 2-3" of snow. I was doubtful my truck would make it up the steepest part of the hill but after a few attempts we spun our way up the rocky section only to get stuck about 50ft from the top where the snow had drifted a bit deeper. After we cleared some of the snow we were able to build some speed



and spin the rest of the way to the top. It was really beautiful to see Weldon in the snow. Only problem was the wind was only blowing about 10mph!

Gradually the wind built up to low 20s and we were able to fly our K2ms. Not long after Daniel, Wayne, Scott, and Tommy arrived the wind picked up some more and occasionally reached the

30mph threshold I had mentally set for the maiden. I decided to make the throw and let Josh fly it out so no one else could be blamed if it went horribly wrong due to a bad throw. It went out perfectly and never even took so much as 1 click of trim on any surface. After a solid 2 years of pondering, what a relief it was to finally see it flying. 🚂

The Transonic DP had no problem cruising around in the wind which had now backed down into the low-mid 20mph range. I played around with the rate switches and found it was actually quite hard to get the plane to drop a tip. I was only able to make that happen by intentionally holding full elevator on my highest rate. Recovery was quick and uneventful. Considering the planform of the wing, I was really relieved to find the slow speed handling to be so docile. The dive test showed barely a hint of positive stability, just the way I like it. This meant it was finally time to dive her into the backside.

In the groove, the Transonic DP reminds me of a super stable overgrown K2m. My previous K130DP models would have been plowing around the circuit not so happily at these speeds but the Transonic actually felt quite nimble even under 200mph. With the plane tracking well, I quickly felt comfortable pulling the turns tighter and the plane locked in really well. Its a very easy to fly model and despite the white paintjob against the snowy background, it was also easy to see. Without digging for it, we managed a top speed of 270mph which I was really pleased with considering we only had 18-25mph wind.

We found that the flaps on the model are really effective and make an awesome Jet turbine type of sound when fully deployed. 🤖 My elevator rate in landing mode turned out to be way too hot but despite some bobbling on the approach, the landing was slow and easy enough in the light air. I'm really impressed with the model's ability to handle light air. I can't wait to fly her in better air and see how it goes with more wind...

Thanks to Josh, Scott, and Tommy for helping out with everything and getting video of the first flight! It was an awesome day with some real adventure, spectacular scenery, good friends, and a very uneventful maiden. 🤖

---

I wanted to put up some photos of the Transonic and the gear installation. It's very similar to what we've done in the past with



a few small changes. This being the first prototype, it's not as clean of an installation as should be possible in the future.

I used all MKS servos with HV747 on the elevator, HV9767 on the flaps, and HV6130 on the outer flap and ailerons. The HV6130 are installed with my aluminum 3rd bearing frames and the others are simply glued in with 3rd bearing supports. I think on future builds, it may be feasible to use HV9767 on the outer flaps but so far the 6130 seems to be holding up nicely in the frames.

On this prototype, I positioned the servo cover recesses very far aft and that made for some extra challenges with the linkages. Because everything was so close coupled, I used two MPJet clevises with the pin repositioned as close as possible to the threaded barrel. In the future, my goal is to machine fixed length solid aluminum pushrods with integral clevised ends.

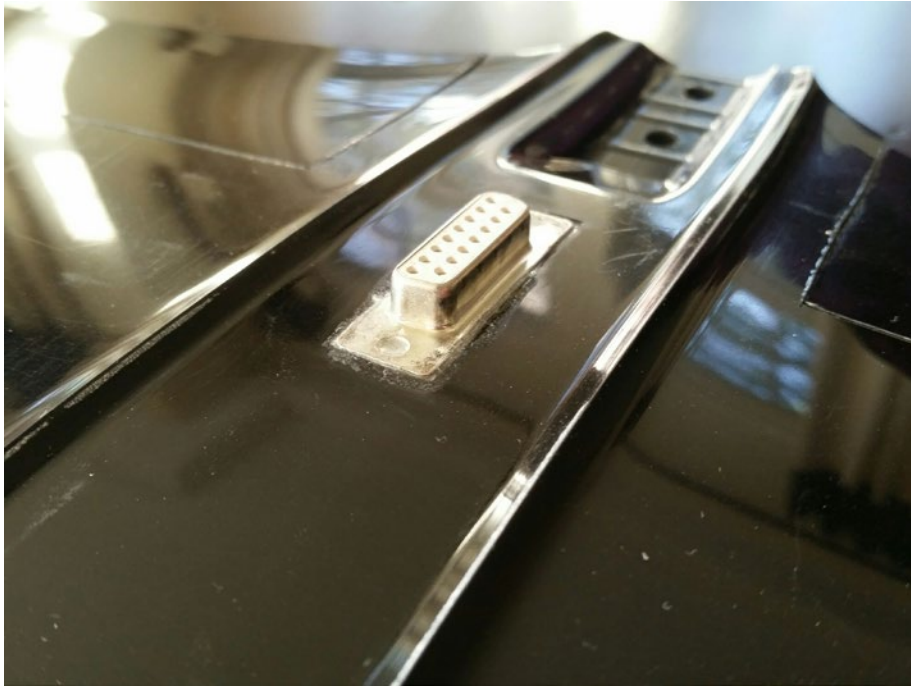

The elevator uses a ball link and carbon pushrod tube just like all the other Kinetic setups. On this model, the elevator control horn is almost 100% recessed into the fuselage. It would be nice to finish this off so its completely clean but it gets pretty tight back there trying to nest a fairing into the cutout.

I decided to make the wing wiring connection plug and play using a 15pin D-sub connector. Alan steered me to a nice high quality piece from Digikey with more robust machined solid pins and cups. Each pin is rated for 5A. The portion inside the fuselage is supported from underneath and trapped inside the oversized cutout so it can float around a couple mm in X and Y axes.

With a 1-piece wing, plug-n-play, and a Zepsus switch, the Transonic takes no time at all to setup on the hill. This has been especially handy with all of the rain we've been getting...

I'm really happy with the solution Thomas came up with for mating the wing to the fuselage. The fit on the outside is so good you don't feel like you're exaggerating when you call it 'Perfect.'

The nose basically holds only lead, battery, and the rx antennae. Since I made as small of a cutout as possible, I was barely able to slide the gear stick into place using (2) 18650 cells. In hindsight, I don't think a larger cutout would be a problem. It would also be possible to add a small access window on the side of the nose in the future if folks think it's preferable to make the install easier.

Current flight history: 448 MPH on her second launch at Parker, breaking the Parker Mountain record; 467 MPH on her third launch.



# THREE BOOKS BY VITTORIO PAJNO

Information courtesy of Paul E. Remde / Cumulus Soaring, Inc.  
<https://www.cumulus-soaring.com>

Sailplane Design, 2nd Edition  
A Guide for Students and  
Designers, From Drafting to  
First Flight

Vittorio Pajno

IBN Editore, 2010

ISBN: 8875650926

Paperback, 479 pages, about  
80 graphs and about 60 color  
photos

Dimensions: 6.7" x 9.4" x 0.8"  
(170 x 240 x 20 mm)

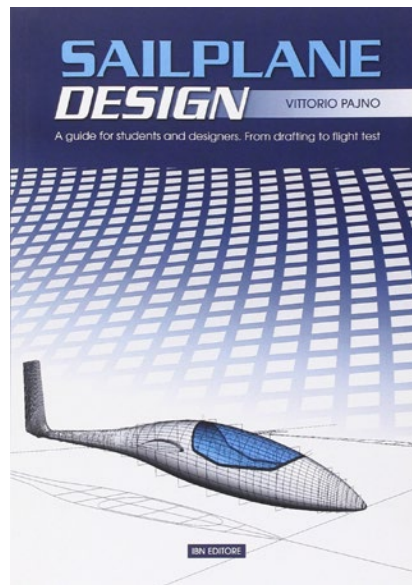

A very complete and thorough “bible” on sailplane design for students and designers. It is similar in concept to the book “Fundamentals of Sailplane Design” by Fred Thomas but (according to the author) this book takes the idea farther and includes practical design examples.

Overview from the Author:

“The book is written with technical language but is addressed to the aviation and gliding lovers with pragmatism - enabling

them really to design a flying machine. A person with a technical background reading the book can really start drafting and calculating a glider. A mass of information is given together with the calculation examples showing “how to do it.” Ancient Romans say “generalia non ledent” i.e. “if you talk generally of principles you don’t compromise yourself.” This book is the opposite: I am specific and I show how to calculate or find further information, giving suggestions also. I have specific experience having designed several gliders as you will see in the photos and computer generated images.

“My aim is to show “how” to design a glider to amateurs and students mainly. Many times, after having had a look at the content of some books you can find at airshows, I bought them just because I like airplanes. The purpose of this book is to provide elements and show the way to follow to design a glider. Theory is supported with concrete examples inside the Chapters and the Calculation Examples support the reader in the theory application.”

Chapter 1 shows how to organize the place where the design of the glider will take place and also methods for producing 1:1 drawings of parts and details to be used during the glider drafting.

Chapter 2 deals mainly with materials and the allowed stresses. Sandwich construction, glues, paints, composite materials

and many other items are treated to avoid waste of time in searching for info.

Chapter 3 has been conceived in order to give to the reader more than the usual basic widespread ideas about flight mechanics.

Chapter 4 deals with aerodynamics.

Chapter 5 is intended as an introduction to Chapter 6. In Chapter 6 the stability calculations are shown in detail, supported by Calculation Examples.

Chapter 7 is a “concentration” of the dynamic stability theory implemented by a practical example of calculation showing mainly “how” to introduce in the equation the terms so every designer can make his own calculations.

Chapter 8 is the heart of the design, i.e. the CS 22 rules.

Chapter 9 shows how to calculate wing, fuselage and empennage air loads.

Chapter 10 deals with flutter.

Chapter 11 is dedicated to the static tests looking at them from two point of view: the amateur and the industrial.

In Chapter 12 the author has collected all his experience in this field and shown in the available literature.

Chapter 13 goes into the certification details showing what is required and how to proceed in Europe.

The Appendix is divided in four sections dealing with instruments, flight manual, maintenance manual and, the last one is of particular and actual importance: the winglets. The latter have been treated in 2005 at the SAS in Milano by Prof. Maughmer. This part of the book Appendix has been entirely made and written by him as well as the photos shown.

Twenty four Calculation Examples provide the backbone of the book showing “how to do it,” which in the author’s opinion is the essence of the engineering.

US\$55 from Cumulus Soaring

Light Airplane and Glider Static and Dynamic Stability

The Aircraft Maneuverability, Basic Theory and Calculation  
Vittorio Pajno

IBN Editore, 2015

ISBN: 9788875652173

Paperback, 179 pages, several black & white images, many drawings, diagrams, tables, and equations

Dimensions: 6.7" x 9.4" x 0.35"  
(170 x 240 x 9 mm)

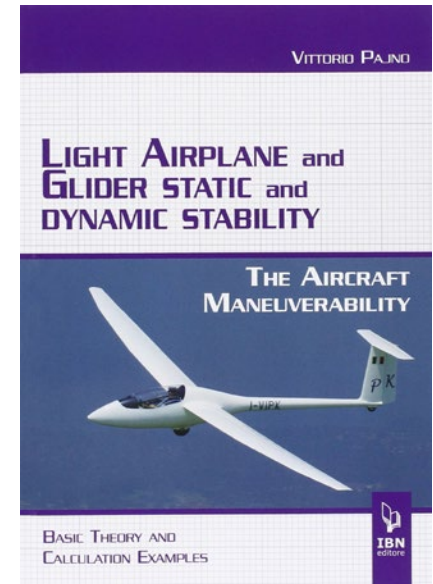

From the Forward by Vittorio Pajno:

“The aim of this book is to provide future designers and students of aeronautical engineering with a practical guide to be used in the study of static and dynamic stability on sailplanes and small aircraft.

“The proposed calculating method is better suited for sailplanes because of their shapes and good aerodynamics. The effect of propellers on the surfaces is a source of errors in the evaluation of moment contributions and stability derivative, thus a correct evaluation of them is very difficult.

“Another problem that is difficult to solve is the evaluation of a lot of theoretical data, which is due to the aeroelastic properties of aircraft. As a matter of fact we consider aircraft as if they were not deformable but we all know that structures are elastic. If we think about it the torsion of sailplanes and the bending of wing and fuselage at maneuverable speed are relevant owing to the peculiar structural slenderness. As for the coupling of the lateral and directional forces and the consequent motions we must consider that the static approach is a limited one. A better approach to this problem can be made by considering a



dynamic analysis. Sample calculations are intended to explain further the already pragmatic approach used in writing the chapters of this book. I hope that the matter so treated can provide a panoramic view of this part of the design of sailplanes and small aircraft: aircraft stability.”

US\$27 from Cumulus Soaring

Sailplane Design Example  
Design Calculation Example,  
Structural Dimensioning,  
Technical Specifications,  
Design Rules

Vittorio Pajno

IBN Editore, 2016

ISBN: 9788875652579

Paperback, 315 pages, many  
black & white images, many  
drawings, diagrams, sailplane  
“transparent views,” tables,  
and equations

Dimensions: 6.7" x 9.4" x 0.6"  
inches (170 x 240 x 15 mm)

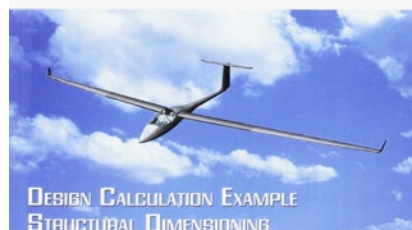

Anyone interested in designing a sailplane will find this book invaluable. It is a great companion book to “Sailplane Design” by the same author.

From the Introduction by Vittorio Pajno:

The book has been divided into four parts: the first one shows the basic content, and the second one describes the historical and technical progress of sailplane design and construction over a century. It is useful to have a look at the past in order to understand how slow progress and the factors affecting it are; it helps us to imagine the future better and to improve the actual state of the art. The third part is intended to show us how to

proceed in order to calculate the various sailplane parts... ..it is an introduction to a possible future project.

“The fourth part deals with the basic structural calculations to be made in order to complete a project. This fourth part has been prepared as simply as possible to make it easily approachable for young people or enthusiasts and amateurs that do not have adequate technical culture.”

US\$50

About the Author:

Vittorio Pajno is a Dr. Ing. graduated at the Institute of Technology of Torino, Italy. He was associated as a student in the “Centro di Volo a Vela del Politecnico di Torino” with Prof. Piero Morelli and has published several books about light airplanes and glider design in the Italian language. The books described here are published in English.

Among several aeronautical activities, he has organized the Motorless Flight Symposium in Varese and the Sport Aviation Symposium at the Politecnico of Milano. He is the designer of the V 1/2 Rondine, shown on the cover of “Sailplane Design Example.”

Cumulus Soaring <<https://www.cumulus-soaring.com>> is offering all three of Vittorio Pajno’s books described here, along with Fred Thomas’ “Fundamentals of Sailplane Design” (English) at a Special Package Price. The Design Bundle is available with a \$30 savings. Purchase “Fundamentals of Sailplane Design,” “Sailplane Design,” “Sailplane Design Example,” and “Light Airplane and Glider Static and Dynamic Stability” at the same time and get \$30 off ( $\$40 + \$55 + \$27 + \$50 - \$30 = \$142$ ).

Design Bundle <Add to Cart> button in the right column at <<https://www.cumulus-soaring.com/books/Fundamentals/Fundamentals.htm>>

# Airfoil System for Cruising Flight

<<http://www.techbriefs.com/component/content/article/ntb/tech-briefs/aerospace/25355>>

Langley Research Center, Hampton, Virginia  
Thursday, 01 September 2016

*Biologically inspired wing flow control uses flexible extended trailing edge.*

Flaps can significantly alter wing aerodynamics for high lift generation. Conventional flaps are mainly deployed for takeoff and landing, but are not suitable for in-cruise flight.

It is widely speculated that birds and insects utilize their wing flexibility, particularly at the trailing edges, for effective control in different regimes. For example, the avian wing geometries of mergansers and owls possess a single layer of feathers extended from an airfoil section of their wings, which improves the global aerodynamic characteristics.

Avian wing geometry inspired the concept of a static extended trailing edge (SETE), where the main airfoil is extended at the trailing edge by attaching a flexible polymer membrane with suitable length and rigidity.

Based upon experimental results and CFD simulation, it was determined that if SETE was implemented on a fixed-wing aircraft, it had the potential to improve cruise flight aerodynamic efficiency up to 10% and reduce fuel consumption up to 5%.

Applied to a typical aluminum airfoil on a fixed-wing aircraft, the technology involves adding a flexible strip that can adjust itself to the airflow to obtain drag reduction.

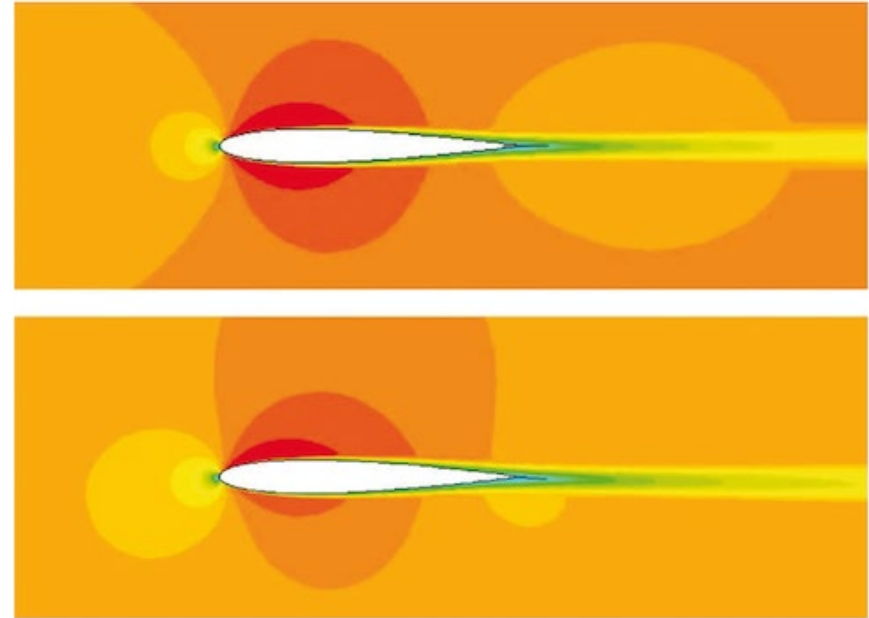

*CFD simulation shows the asymmetry of the flow field induced by SETE where wake is turned downward, indicating a deflected momentum stream tube and generation of additional lift.*

Alternatively, sensors and actuators can be used for feedback control to make adjustments to the strip to optimize drag reduction.

Depending on specific applications, the strip could be made of an aluminum plate, polymer membrane, composite sheet, or smart material plate.

The effects of SETE on the wing aerodynamics are mainly due to modifications of the airfoil camber and of the flow structure at the trailing edge. The resulting improvement in aerodynamic efficiency leads to greater fuel efficiency and vibration control.

For small aircraft like unmanned aerial vehicles (UAVs), the device can prevent flow separation, which can lead to stalling.

The figure shows the asymmetry of the flow field induced by SETE where wake is turned downward, indicating a deflected momentum stream tube and generation of additional lift. The wake structure is not appreciably altered, indicating that the parasite drag is not significantly affected.

This SETE airfoil system can be used in fixed-wing aircraft, helicopters, wind turbines, and UAVs.

NASA is actively seeking licensees to commercialize this technology. Please contact The Technology Gateway at LARC-DL-technologygateway@mail.nasa.gov to initiate licensing discussions.

Follow this link for more information:  
<http://technology.nasa.gov/patent/TB2016/LAR-TOPS-146>.



# New 60" Dynamic Soaring Record



|                |                             |
|----------------|-----------------------------|
| Location/Date: | Weldon CA, 06 February 2017 |
| Pilot:         | Bruce Tebo                  |
| Witness:       | Scott Magner                |
| Plane:         | Storm Chaser 60 inch        |
| Speed:         | 369 mph                     |
| Radar:         | Stalker Pro2                |
| Winds:         | 40-50 mph                   |

Thanks to David Vels, davidjvels@hotmail.com, via the MRSSA Yahoo! Group, for the initial information. Thanks also to Scott Magner for his postings at RCGroups.com <<http://tinyurl.com/zqkoyq4>>



On the 'Wing...

# The Integrated Minimum Drag Solution

*New Wing Design Exponentially Increases Total Aircraft Efficiency*

<<http://www.techbriefs.com/component/content/article/ntb/tech-briefs/aerospace/25358>>

Bill & Bunny Kuhlman, bsquared@centurytel.net

Armstrong Flight Research Center, Edwards, California  
Thursday, 01 September 2016

Innovators at NASA's Armstrong Flight Research Center are experimenting with a new wing design that removes adverse yaw and dramatically increases aircraft efficiency by reducing drag. The technology has the potential to significantly increase total aircraft efficiency by optimizing overall aircraft configuration through the reduction in size or removal of the vertical tail, as well as the reduction of structural weight.

Adverse yaw, present in current aircraft design, is the horizontal movement around a vertical axis of an aircraft in the direction opposite a turn. As an aircraft banks, differential drag creates adverse yaw. Pilots must employ some form of yaw control to counteract this effect. Unfortunately, this yaw control introduces another form of drag that degrades performance. However, a wing with proverse yaw (that is, force in the same direction as the turn) does not need such control and thus helps optimize aircraft efficiency.

The Armstrong team (supported by a large contingent of NASA Aeronautics Academy interns) built upon the 1912 research of the German engineer Ludwig Prandtl to design and validate a scale model of a non-elliptical wing that reduces drag and increases efficiency. Known as the PRANDTL-D wing, this design addresses integrated bending moments and lift to achieve a 12 percent drag reduction. The approach to handling

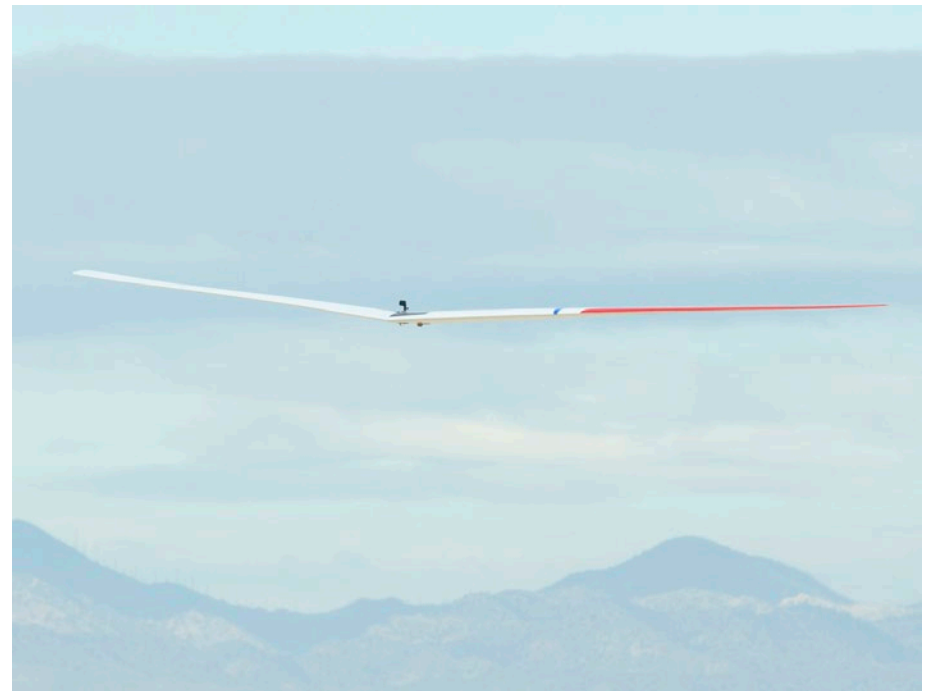

*PRANDTL-D during data collection test flying.*

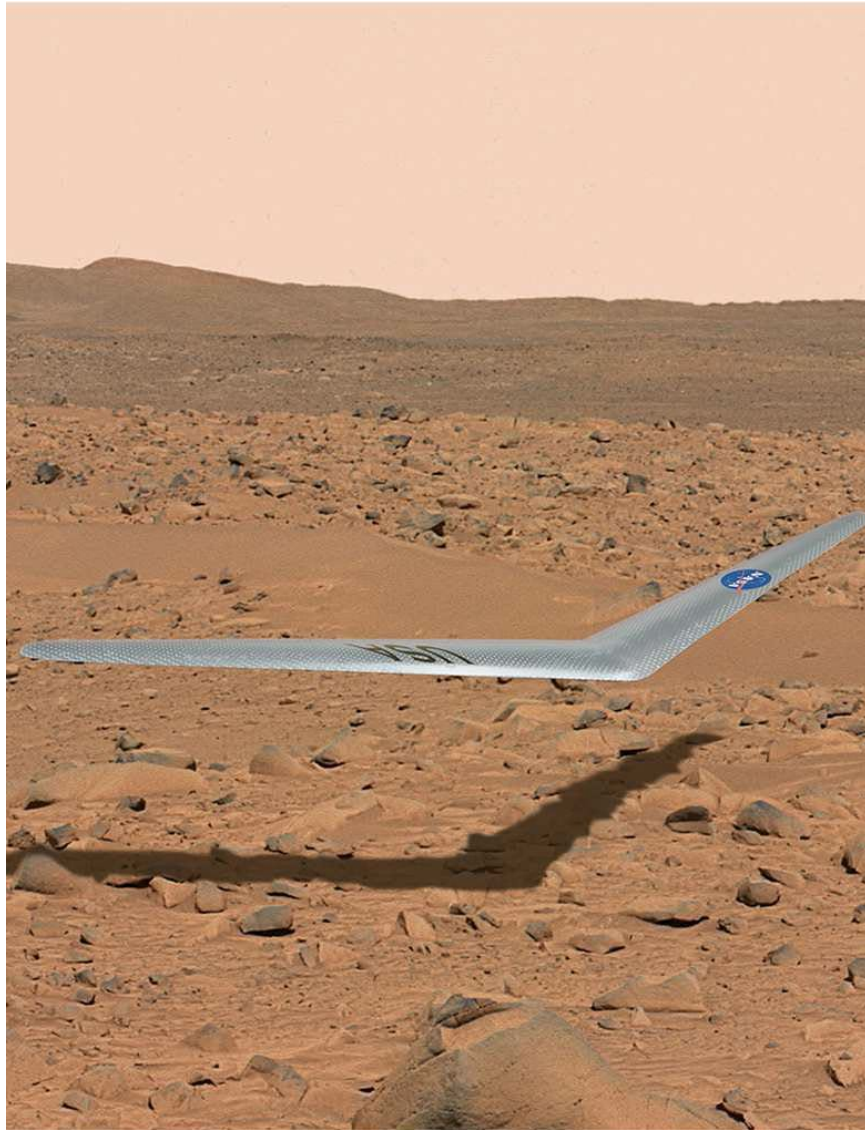

*PRANDTL-D on Mars*

adverse yaw employs fine wing adjustments rather than an aircraft's vertical tail.

As a proof-of-concept, the PRANDTL-D team demonstrated proverse yaw during a live flight test in June 2013. The remote-controlled aircraft had a bell-shaped spanload and no vertical surfaces of any kind.

The key to the innovation is reducing the drag of the wing through use of the bell-shaped spanload, as opposed to the conventional elliptical spanload. To achieve the bell spanload, designers used a twisted and sharply tapered wing, with 11 percent less wing area than the comparable elliptical spanload wing. The new wing has 22 percent more span and 11 percent less area, resulting in an immediate 12.5 percent efficiency gain. Furthermore, using twist to achieve the bell spanload produces induced thrust at the wing tips, and this forward thrust increases when lift is increased at the wingtips for roll control. The result is that the aircraft rolls and yaws in the same direction as a turn, eliminating the need for a vertical tail to provide yawing moment. When combined with a blended-wing body, this approach maximizes aerodynamic performance, minimizes weight, and optimizes flight control.

The commercial potential for this technology is strong. Adopting the bell-shaped spanload change will result in an immediate 12 percent drag reduction. In addition, optimization of the overall aircraft configuration, as well as extension of the concept to propulsion systems, is projected to result in significant overall performance increases. Applications to wind turbines and fans are also being explored.

This work was done by Al Bowers of Armstrong Flight Research Center. NASA is actively seeking licensees to commercialize this technology. Please contact the NASA Armstrong Technology Transfer Office at 661-276-3368 or by e-mail at [AFRC-TTO@mail.nasa.gov](mailto:AFRC-TTO@mail.nasa.gov) to initiate licensing discussions. Follow this link for more information: <http://technology.nasa.gov/patent/TB2016/DRC-TOPS-36>. DRC-012-027.

# TOM'S TIPS

## Center between two holes

Tom Broeski, T&G Innovations LLC, tom@adesigner.com

On more than one occasion, I've watched someone trying to measure the center between two holes by eyeballing the empty space and guessing the exact center. The other day this happened again (he was a millimeter off when I measured it). Sooo, I've decided to go ahead and mention this for the 10% (or more) that don't know this simple fact:

**The distance between the centers of two like holes is the same as the distance between the like edges...**

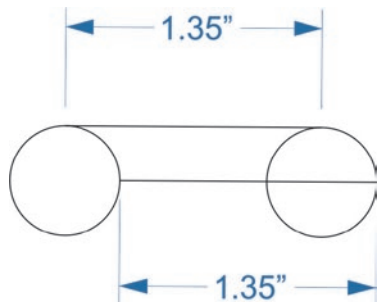

The edges are a lot easier to see and measure, so next time try measuring between the left or right edges.

Instead of doing this:



Try this:

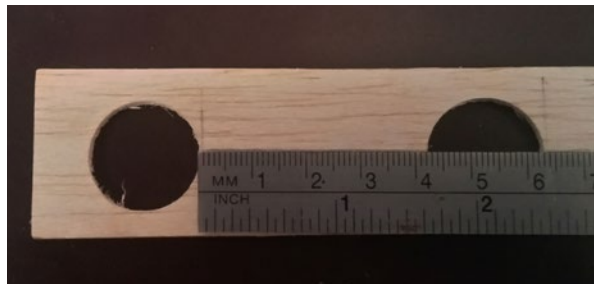

### Different diameter holes

For things like root ribs where the two holes are often different diameters (based on the easiest things to measure):

Take the sum of the diameter of each hole, divide by 2; add the distance between the inside edges.

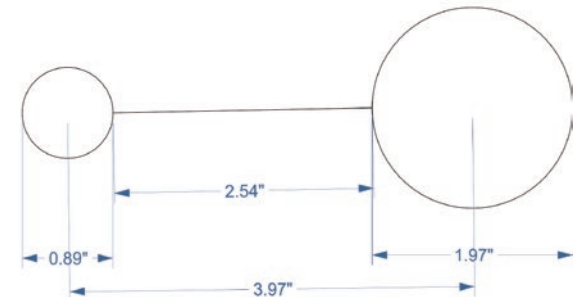

$$(0.89 + 1.97)/2 + 2.54 = 3.97$$
$$(r1 + r2 + d1 = c1)$$

# Slope Soaring Candidate

## Archangel 1

In 1954, CIA retained the Lockheed Corporation to build the U-2 reconnaissance aircraft. The U-2 could fly at 70,000 feet and take detailed photographs of Soviet Bloc military facilities. The aircraft operationally ready in June 1956, but was almost immediately tracked by Soviet defense systems.

It was obvious a more radical solution was needed in the form of a new airplane.

Lockheed's Advanced Development Projects began designing an aircraft capable of Mach 3 at altitudes above 90,000' in early 1958, and a number of configurations had been studied by September of that year. Based on the code name for the U-2, "Angel," these initial designs were designated "Archangel-1," "Archangel-2," etc.

The eventual accepted design proposal, A-12, was produced by Lockheed as the SR-1 "Blackbird" and variants with which aeromodellers are familiar. With a range of about 4,600 miles, the A-12 top speed was listed as Mach 3.2 at up to 97,600'. The SR-71 became operational in 1964.

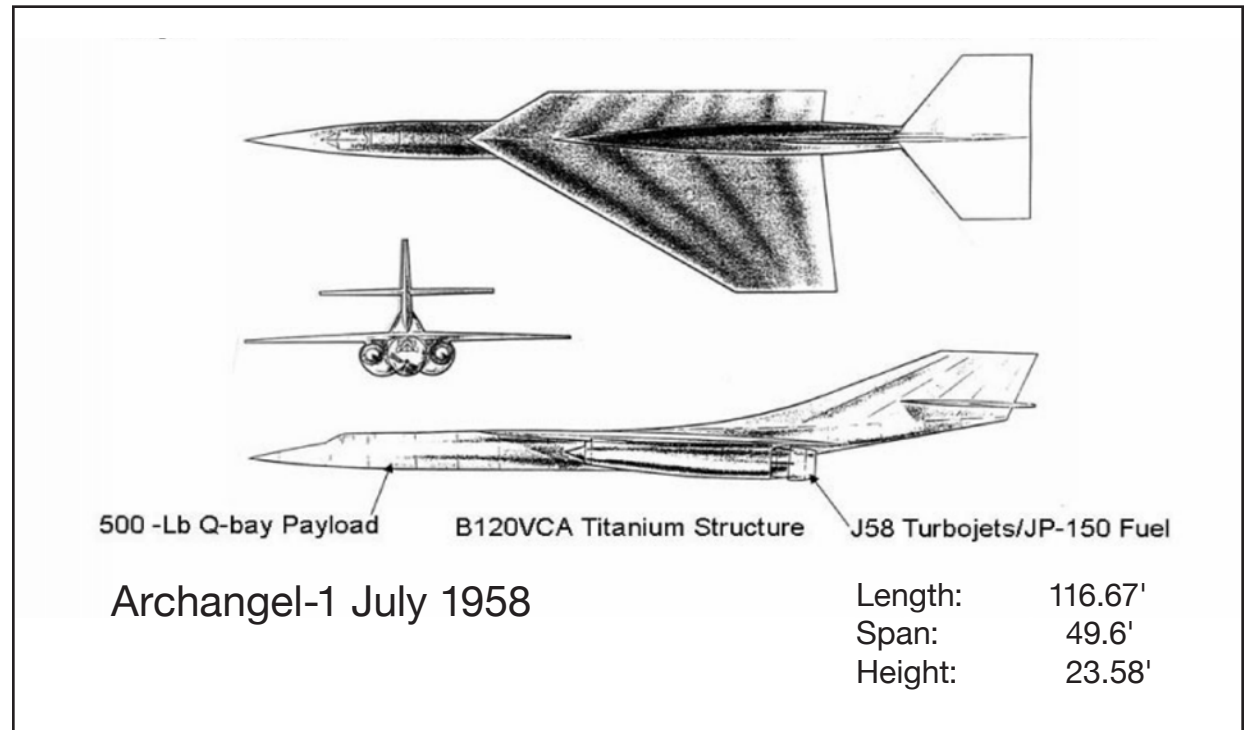

Resource:

Archangel: CIA's Supersonic A-12  
Reconnaissance Aircraft, Second Edition  
David Robarge, CIA Chief Historian  
Central Intelligence Agency, Washington  
D.C., 2012  
ISBN: 978-1-929667-16-1

With the TAKEO we present a new, unique model concept!

TAKEO can be used as a pure glider as well as an electric sailplane.

The model has a split fuselage, as well as four-part wings. This makes it easy to transport in a special aluminum case (included in the scope of delivery!), and is therefore perfectly protected during transport in car, airplane on holiday or for storage at home.

So to speak, an ever-present model!

The case is still so spacious that even small chargers, transmitter, or other accessories have a place. Thus, the model is always stored ready for flight!

The ruddervators are mounted directly in the VLW (V-Lietwerk) as already demonstrated on our Orca eVo and Satori-eVo. This makes the model with the appropriate electrical plug connections quickly built up and then has a wingspan of 3.60m!

The design is robust with carbon construction and a 2.4-friendly fuselage nose!

Takeo (including aluminum case)... €1650.

