

Radio Controlled
Soaring Digest

February 2023

Vol. 38, No. 2



The New RC Soaring Digest

February, 2023
Vol. 38, No. 2

| Title | Subtitle | Page |
|--|---|------|
| In the Air | There is reason and purpose to all things. | 3 |
| Letters to the Editor | An answer, another question and somebody whose folks definitely raised him right. | 8 |
| Cool New Stuff | New products that will fill you with enthusiasm without emptying your wallet. | 12 |
| Building the Rico-SHE LW | Part II: Finishing and Flying the Classic from Phoenix Model Products | 20 |
| Downsizing the Bergfalke IV | Part II: So how did it all pan out? | 41 |
| Dream 2700 A Tailless Tale | Part IV: The Sky Awaits! | 47 |
| Project ALTius | Part I: A simpler approach to high-performance glider development using CAD/CAM. | 56 |
| The Hustler | Your opportunity to build a classic design from the golden age of RC sailplanes. | 64 |
| Twist Distributions for Swept Wings | Part 1: Why place proportionally more twist in the outboard portion of the wing? | 84 |
| Replacing a Wing Servo in a Glass Slipper Wing | Tired of hassling with servo frames in ridiculously tight spaces? | 94 |
| Science for Model Flyers | Part IV: Aerials | 105 |
| Soaring the Sky Podcast | E093: Monkeys, Coconuts, Field Fires and John Denver An Interview With Don Ingraham | 136 |
| Condor Corner | Introduction | 139 |
| Five Minute Fixup | Frequent RCSD Contributor Marc Pantan Kicks Off a New, Informal Series | 143 |
| Stamps That Tell a Story | Philatelic tributes to aviation pioneer Octave Chanute. | 152 |
| Glider Patents | US 4061028 A: Aircraft Total Energy Sensor | 160 |
| The Trailing Edge | Life according to Jerry Seinfeld. | 180 |

Click on any row to go directly to that article.

In The Air



Alexis Scott's ASW 15 'special' over Tapanappa, South Australia on January 29, 2023. See details in the article below. (credit: Zoe Molloy)

There is reason and purpose to all things.

A funny thing happened today as we were scrambling to get the February issue 'off stone' as they say in the UK. We had one important update for which we were waiting confirmation – it may not yet come, who knows – so we stopped the presses for 24 hours just in case it did. In addition to the aforementioned tardy update, we had the release on a set of pictures fall through, at least for this month. It was at *that precise moment* an email came in which instantly reminded me of a line from my favourite TV show:

“I used to think that the universe is a random, chaotic, sequence of meaningless events, but I see now that there is reason and purpose to all things.” – Seinfeld

In that email was the offer of a beautiful, zillion pixel photograph to replace the ones for which we couldn't nail down the release – it's kismet! See the result above – it was just taken by Zoe Molloy.

Thanks Zoe for such a beautiful photo and to Alexis Scott – whose unique ship is pictured – for initiating this serendipitous turn of events! We turn it over to Alexis to describe the picture in a bit more detail:

“This was taken at one of our amazing coastal sites here in South Australia, called Tapanappa. The model is my 1/3-scale Airworld *ASW 15* ‘special’. The special is because it’s based on a full-size version belonging to my friend Mark Stanley who restored it many years ago. During the restoration he added Grob canopy hinges rather than the lift off canopy of a standard *ASW 15*. The photo was taken by a lovely young lady, Zoe Molloy, who is the daughter of another friend who has made a couple of videos of the day and this model as well as my Baudis *Salto*”. We’ve linked the videos in *Resources* below.

Broadening the Editorial Footprint

I have always assumed a substantial majority of those who participate in RC soaring do so without aspiring – even for a second – to fly full-size gliders. The joy of the ‘next best thing’ is knowing that it’s not ‘next best’ at all. It’s a worthwhile pursuit in and of itself. After all, what else can make the hair stand up on the back of your neck like seeing your supership core in and the vario squeal with delight all with your feet planted firmly on the ground.

That said, there will be some for whom RC soaring is a pretty good alternative to flying the real thing, but not quite the same thing at all. These folks might find the cost of full-size flying prohibitive. They may have some sort of medical condition which prevents it. Or there may also be those who can’t quite overcome some fear they have. Whatever the reason – after all, it’s really none of our business – there is another pursuit which has many of the same rewards as RC gliding plus something which inches toward the real thing: glider flight simulators.

These are not your grandfather's flight sims: some versions offer wraparound video and full motion which really puts you in the pilot's seat. They can also be more modest affairs which you run on a laptop, say, while enduring the endless, bus-with-wings flight to Paducah. Suffice to say at either end of the spectrum, there's lots to explore and – dare I say it – a lot of fun to be had not to mention some valuable education applicable to gliders of all sizes.

The New RC Soaring Digest has already dipped its toe into this subject, with a couple of episodes of Chuck Fulton's *Soaring the Sky Podcast* which RCSD readers really seem to be enjoying. The first episode features Chris Wedgwood of *Condor*, the glider flight simulator software company. The second features Scott Manley, who makes at least part of his living using glider simulation – including *Condor* – to teach soaring. See *Resources* for links to these and both episodes are well worth your time. Actually, *all* of Chuck's episodes are worth your time!

However, starting this month we're going to take our toe out of the water and instead dive in head first. Scott Manley – from Chuck's podcast noted above – has agreed to let the New RC Soaring Digest run his series called *Condor Corner* which will continue for the foreseeable future and focus on various aspects of glider flight simulation. I'd like to personally welcome Scott to our contributor ranks and thank him for his enthusiasm for this project. It's going to be a great series!

I also intend for the New RCSD to continue to seek out excellent glider sim content and feature it on these pages for all – both RC and full-size (or both!) pilots to enjoy. And in a late, breaking development to that end, also check out the *Yawman* in *Cool New Stuff* this month. Great for that endless flight to Paducah.

Bill Kuhlman's Return to These Pages

Despite numerous mentions, I realise there may still be a few out there who don't recognise Bill's name. I also realise the majority of you do, given Bill along with his wife Bunny edited the RC Soaring Digest for many years. What I have perhaps neglected in the previous mentions of Bill is that he was also a huge contributor to RCSD in addition to being one of its tireless editor. For that reason, I was delighted when Bill suggested we re-run his remarkable *Twist Distributions for Swept Wings* series. Bill is a meticulous researcher and an excellent writer as well as a talented illustrator. Therefore, I'm thrilled this issue includes the first of five parts of this series which will run over the coming months. I hope it's the first of many articles we can re-launch on the New RCSD platform. Also, dare I dream for some new articles from Bill? My fingers are crossed and yours should be too!

On with The Show!

As usual, I have done a pretty good job of getting in the way of the stuff you *really* want to read. But I would be remiss if I didn't thank all of our contributors, new and old, for all of their hard work on the February issue. I know I say it every month – but it's also **true** every month – that this issue is the best one yet. Also, I would be remiss if I didn't also extend my humble thanks to *you* for reading it all.

Fair winds and blue skies!

A handwritten signature in black ink, appearing to read 'Tony', with a long horizontal stroke extending to the right.

©2023

Resources

- [ASW 15](#) video by Molloy RC. – Your opportunity to see Alexis Scott's magnificent ASW 15 soaring over Tapanappa, South

Australia as pictured in the key photo above. You have simply **got** to see this flying site which is brought to life in this very professionally made video with a very cool soundtrack.

- [Baudis 1/3-scale Salto 4.1m at Tapanappa, South Australia](#) video by Molloy RC. – Shot in the same location as above, this time featuring a racy Baudis *Salto*. As with Molloy RC's first video, this one also has very high production values. This flying location is now officially on our bucket list – South Australia here we come!
- [E047: Condor Soaring Flight Simulator with Chris Wedgwood](#) from the *Soaring the Sky Podcast*. – Chuck Fulton's interview with Chris Wedgwood of glider flight simulator company *Condor*.
- [E129: Soaring and Simulation | Getting the Most Out of Your Simulator Experience](#) from the *Soaring the Sky Podcast*. – Chuck Fulton interviews Scott Manley who uses *Condor* and other glider flight simulators to teach full-size soaring skills.

Cover photo: *This month's spectacular cover photo was taken by frequent and highly regarded New RCSD contributor Chris Williams and features a picture of his new 1/6th-scale Slingsby Kite seemingly flying above the clouds where it's CAVU – clear and visibility unlimited all the time. You are welcome to download the February 2023 cover in a resolution suitable for computer monitor wallpaper. ([2560x1440](#)).*

Disclaimer: *While all reasonable care is taken in the preparation of the contents of the New RC Soaring Digest, the publishers are not legally responsible for errors in its contents or for any loss arising from such errors, including loss resulting from the negligence of our staff or any of its contributors. Reliance placed upon the contents of the New RC Soaring Digest is solely at the readers' own risk.*

Here's the [first article](#) in the February, 2023 issue. Or go to the [table of contents](#) for all the other great articles. A PDF version of this edition of *In The Air*, or the entire issue, is available [upon request](#).

Letters to the Editor



Can you spot the new addition?

An answer, another question and somebody whose folks definitely raised him right.

An Answer to Peter Scott's Turbofan Question

Peter Scott, in his most recent *Science for Model Flyers* column, asks why model gas turbines use fuel so much faster than their IC counterparts. The answer is that they are very inefficient machines.

A modern full-size turbofan has a compression ratio above 40:1, a large fan to move air very efficiently and internal aerodynamics, fits and finishes that optimise airflow and minimise leakages. Our model turbine has, at best, a compression ratio of 3:1 or 4:1 and is designed to start and run reliably rather than being optimised for efficiency. The model turbine is much like the original Whittle engines from the 1940's. Very simple devices that worked well but were a long way from the complex and ultra optimised aero engines of today.

Many thanks for a great magazine every month.

Mike Goulette
United Kingdom

Mike's letter had a real ring of authority, and in a subsequent email chat he humbly offered that "I'm glad that my 45 years at Rolls-Royce have proven to be useful!" I don't think Mike will mind if I also add his further comment: "Most of my career was UK based, however, I ran the R-R office in Seattle from 2000 to 2004 and flew with the Seattle Area Soaring Society at 60 Acres Park. I retired in 2010 as one of the senior engineering directors in the Company. I loved my time at R-R which took me all over the world but, looking back, it's the people I miss the most!" Talking with people like Mike, alone, makes this job worth doing. – Ed.

A Question about a Graupner Classic

I was looking through some plans on Outerzone and came across a very interesting (and I daresay challenging!) subject for a scratch build: the Graupner *Mosquito* 2.5m span of 1975 (linked in *Resources*) with some modern electronics such as BLDC motor, micro servos and the like.

I might work with a foam wing, with a D-tube construction – 1.5 mm balsa sheeting from leading edge to spar, balsa leading and trailing edge, and some spars either in carbon fibre or bamboo, or a conventional balsa built-up wing.

I was wondering if anyone had any tips on a wing joiner arrangement. The one shown in the plans is just 3+3" long and about 3/16" (5mm) diameter of unspecified material. Lots of doubts there.

Thanks in advance for anybody able to help.

Sanjay
Gurgaon, Haryana, India

Okay, readers over to you. You did a bang up job with Norrie Kerr's Anthem question a couple of issues ago. Who can help Sanjay out?! – Ed.

Speaking of Norrie Kerr

Just a quick thank you to all involved I now have the *Anthem* plans on a memory stick and will be going to the print shop very shortly.

Regards,
Norrie Kerr

*On behalf of all who were involved, Norrie, you're **very welcome**. Thanks for the opportunity to help you out – it has had the spin-off benefit of being able offer the Anthem plans to **everybody**. There is one condition, however: you have to provide regular updates on how that Anthem project! – Ed.*

Resources

- [Science for Model Flyers / Part III: Energy](#) – Peter Scott's article in which he posed his gas turbine question and for which Mike Goulette provided such an excellent, informative answer.
- [The New RC Soaring Digest / January, 2023 / Vol. 38, Nº1](#) – The post to *RC India* which served as the impetus for Sanjay's question above. *RC India* is a great resource you should check out!
- [Mosquito](#) from Outerzone. – “A very good model manufactured by Graupner. One of the first electric gliders...”
- [Bob Dodgson's Anthem](#) (1.5MB PDF) – The plans as they were originally delivered with the kit. A local print shop should be able to transfer them to paper at a reasonable cost. These are also available [in colour](#) which can be used to distinguish the various types of annotations.

Send your letter via email to NewRCSoaringDigest@gmail.com with the subject “Letters to the Editor”. Alternatively, you can leave a reply

in the Responses section below (that's the little ). We are not obliged to publish any letter we receive and we reserve the right to edit your letter as we see fit to make it suitable for publication. We do not publish letters where the real identity of the author cannot be clearly established.

*All images by the author unless otherwise noted. Read the **next article** in this issue, return to the **previous article** in this issue or go to the [**table of contents**](#). A PDF version of this article, or the entire issue, is available [**upon request**](#).*

Cool New Stuff



The Maverick ready to tackle the booming thermals over Ternopil, Ukraine. (credit: FlightPoint)

New products that will fill you with enthusiasm without emptying your wallet.

Maverick Full House F5K

A long list of requirements addressed in an economical airframe.

Since the F5K and eDLG classes started rapidly gaining popularity, FlightPoint of Ukraine had the idea of having a budget model which would address a number of important requirements with a single airframe:

- Easy to build as this design is intended for beginners
- Low weight and low drag to give it an advantage on the competition circuit
- A 'full house' wing with modern airfoil to allow for camber adjustments and wider flight envelope for both sport and competition flying

- Rigid construction to withstand high-G manoeuvres often experienced during those challenging upwind slogs
- Compact size of a complete model to make it easy to transport
- Use of low-cost drone components for the powertrain and a wide range of servo choices to keep it affordable
- Last but not least, a compact shipping package to enable delivery worldwide even with the ridiculous cost of shipping these days

The result is the *Maverick Full House F5K* – a balsa wood airframe primarily consisting of relatively easy to obtain 2mm, 3mm and 6mm sheets. They also added some cost-efficient, standard-size carbon fiber tubes and rods for added strength to the wings, especially on the leading and trailing edges. Despite robust strength, it came in at just 330g all up weight for a complete 1.5m glider.

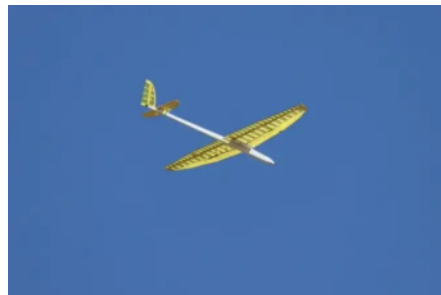

Click on any one of these FlightPoint-provided photos for a more detailed view. The centre photo is Australian Andrew Newton's modified straight wing Maverick intended for the slope, taken by his buddy Arthur.

The original design featured a polyhedral wing, which FlightPoint feels is optimal for thermal flying. *Maverick* can easily use only tail control surfaces to circle in thermals. However, since the airfoil allowed for nice reflexed camber settings, it serves the pilot as a competent slope flyer as well. To that end, FlightPoint has an optional *Warmliner Conversion Kit* to make the *Maverick* a straight wing sloper as shown above.

You can obtain additional information about the *Maverick Full House F5K* from [FlightPoint](#).

Bernd Backpack

The model aircraft backpack with brand new features for 2023.



Stich & Faden of Malsch, Germany has further developed their popular *Bernd* backpack and now offers it with additional options for 2023: integrated carrying straps, side tubes tailor-made for glider fuselages and an ultra-light, ultra-thin rain cover are all now available to order.

For those not familiar with *Bernd*, it has a length of 80cm and a cross-section of 30 x 12cm. Two sewn-on pockets with zips offer space for your transmitter as well as tools and small parts. On the standard model, there are sewn-on webbing straps with carabiners on the side

facing the back. This allows the backpack to be attached to another hiking backpack, for example.

The outer layer of the rucksack is made of a robust Oxford polyester fabric, available in six colours. The material is waterproof, durable, abrasion and tear resistant and does not fade in sunlight. The backpack also has an inner layer of soft, industrial-quality needle felt and an approximately 10 mm thick inner layer of volume fleece in the bottom. In a throwback to days where craftsmanship was more than just an empty buzzword, every *Bernd* is made by hand in their own workshop. More information is available from [Stich and Faden](#).

Portable Dust Collector

Exorcise that dust devil of balsa shavings.

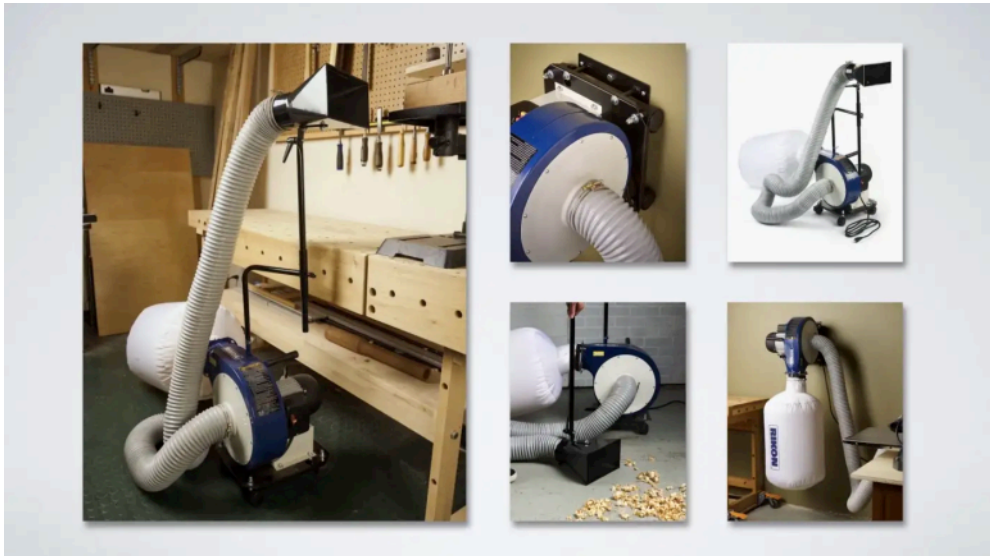

The Rikon Portable Dust Collector. (credit: Lee Valley)

We have made no secret of the fact that we love days when the latest Lee Valley catalogue lands with a thunk on the office step. What usually ensues is low-energy fisticuffs to see who gets to read it first before it lands in the throne room for second reading.

After the post box brouhaha, what caught our attention in the most recent tome is this *Portable Dust Collector* from Rikon. Old school builders who are still burying themselves in balsa dust – or the 21st

century analogues of same – will appreciate being able to use the 9' long, 4" inch diameter hose to move the dust collection to your project as opposed to the other way 'round.

According to the catalogue description the base unit has a footprint of only 14 1/2" × 18" × 19", and the 16" × 22" collection and filter bag traps particles as small as 2µm (microns) and it is capable of moving up to 660cfm while only producing an air condition-like 78 dB. It's a beefy unit, though, weighing in at 48lb without accessories. More information is available directly from [Lee Valley](#).

Gaming Controller Designed for Flight Simulators

Level up your sim game with this 'hand-held cockpit'.



(credit: Yawman)

The Yawman *Arrow* is a new type of hand-held gaming controller. There's a lot of great hardware out there for virtual flying, but none that you can bring with you. The *Arrow* combines all the traditional flight controls of an aircraft and melds them into a to-go package. From an integrated trim wheel to mechanically linked triggers for precise rudder control, Yawman has added seven axes and 21 buttons into an ergonomic shape that reflects one of the tenets of good flight

deck design – deliver tactile feedback when flying so an aviator always knows the state of their aircraft.



(credit: Yawman)

For the upcoming *Arrow*, all of this has been designed into a package that can easily come with you when you travel away from home (or to your couch) or sit discreetly on your desk. By simmers for simmers, the *Arrow* is optimized for PCs and laptops running Windows and MacOS, as well as Android tablets running the most modern sims like *Microsoft Flight Simulator*, *X-Plane*, *Infinite Flight*, and *Prepar3D*. The *Arrow* is designed, manufactured and packaged in the USA and will be available in the spring of 2023.

More information is available directly from the [Yawman](https://yawman.com) website.

Shed Head Shop Apron

An errant drop of epoxy ruined your brand new cashmere sweater?



Is balsa dust your constant companion even when you're finished sanding for the evening? Perhaps you need a space to stash a snack and a flask (or two flasks) before you head out to the shop for the evening? Or do you simply want to look good while working on your latest creation?

If **any** of the above applies to you then the RC Soaring Digest *Shed Head Shop Apron* is the bold response to these common RC soaring shed challenges. Order this beautiful, 100% organic cotton apron and rock your shed in style! More information can be obtained from [The New RCSD Shop](#).

This product is made especially for you as soon as you place an order, which is why it is fairly priced and takes us a bit longer to deliver it to you. Making products on demand instead of in bulk helps reduce overproduction, so thank you for making thoughtful purchasing decisions!

Say you saw it in the New RC Soaring Digest.

***The Fine Print** All product descriptions in Cool New Stuff are prepared in collaboration with the product's manufacturer and/or distributor which is/are entirely responsible for ensuring the accuracy of their product's descriptive text and images contained herein. Note also the New in Cool New Stuff can sometimes mean 'new to us' – the French nouvelle as opposed to neuf.*

Would you like your product featured in Cool New Stuff? Please [contact us](#). Read the [next article](#) in this issue, return to the [previous article](#) in this issue or go to the [table of contents](#). A PDF version of this article, or the entire issue, is available [upon request](#).

Building the Rico-SHE LW



The finished Rico-SHE with the exquisite, rolling English countryside in the background.

Part II: Finishing and Flying the Classic from Phoenix Model Products

Readers who want to know the story so far may want to read [Part I](#) of Marc's article before proceeding with the article below. – Ed.

Last time we finished at the stage of having the the fuselage and wings built and covered with cross weave tape. The 'to-do' list still had a few things to tick off: ailerons, final coverings, radio fit out, centre-of-gravity (CG) balance and – of course! – maiden flight and fine tuning.

Give Me Some Direction

The *Rico-SHE* is a 'bank and yank' style of glider; the control surfaces are simply full span ailerons and a elevators on the V-tail. Note that this is **not** elevons/ruddervators – there's no rudder function. The kit is supplied with trailing edge stock for the ailerons that needs a little

bit of work to get a top notch build. You *could* use 'as is', but this is model engineering, not ~~røcket-science~~ Twitter, we want to do things properly!

Due to the taper of the wing from root towards the tip, the thickness of the aileron needs to reduce as it runs outboard to match the false trailing edge of the main wing section. At the same time, the actual trailing edge thickness needs to be maintained – to avoid it getting too fragile – and the plan form of the aileron needs to remain. Lastly, aileron needs a rebate to allow for travel with a **top** hinge†. Half an hour with the with a large sanding block and some 80–120 grit paper gave the required shaped ailerons, ready for covering.

*†Word of caution: the photos show a mock up with **bottom** hinges.*

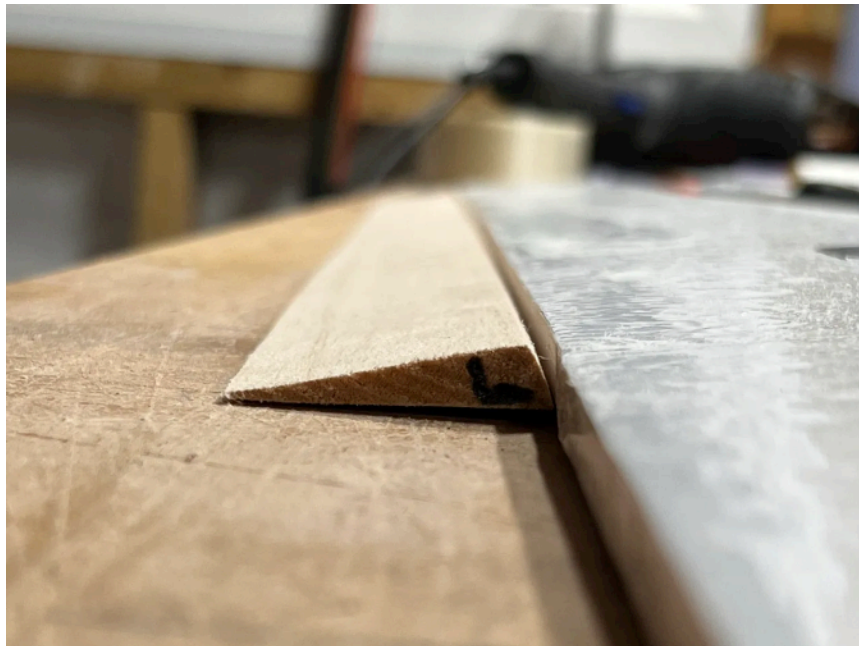



The shaped ailerons with rebate for hinge/movement. Note that what is shown is for bottom hinges, but top hinges were used.

I'll Get My Coat

The traditional covering method for many of the PMP kits is packing tape. It's readily available, fairly cheap, easy to apply (no special tools or irons needed) and comes in many colours beyond 'parcel brown' if you search online. You could also use any of the other 'classic' covering films or even brown paper and PVA. I'm sure they'd all work just fine. I however, instead, chose vinyl.

I've used vinyl on a few of my gliders over the last few years. I find it easier to apply, harder wearing, and cheaper than the 'normal' RC covering materials. Cleaning is easy: just wipe down with a damp cloth, or even a bit of WD40 for harder stains. For scratches, a quick blow from a hairdryer or very gentle judicious use of a heat gun will soften the vinyl and allow it to almost heal itself, much like 'paint protection film' used on cars. Perhaps the biggest benefit is the diamond pattern in the adhesive on the brand I use. It's almost impossible to get air bubbles because the trapped air can escape via the groves. See photos below for further details.

When I mentioned this to others in the hobby, one of the first questions asked is “isn’t it heavy?” Well, yes and no: **yes**, it is heavier than typical iron on coverings, but that’s less of a concern for most of my slope soaring activities – a little extra weight normally isn’t an issue! **No**, 25g (0.75oz) glass cloth and the relevant epoxy, primer, some filler and paint top coat is broadly the same finished weight as the equivalent vinyl area. It might be a touch lighter, but not a huge difference.

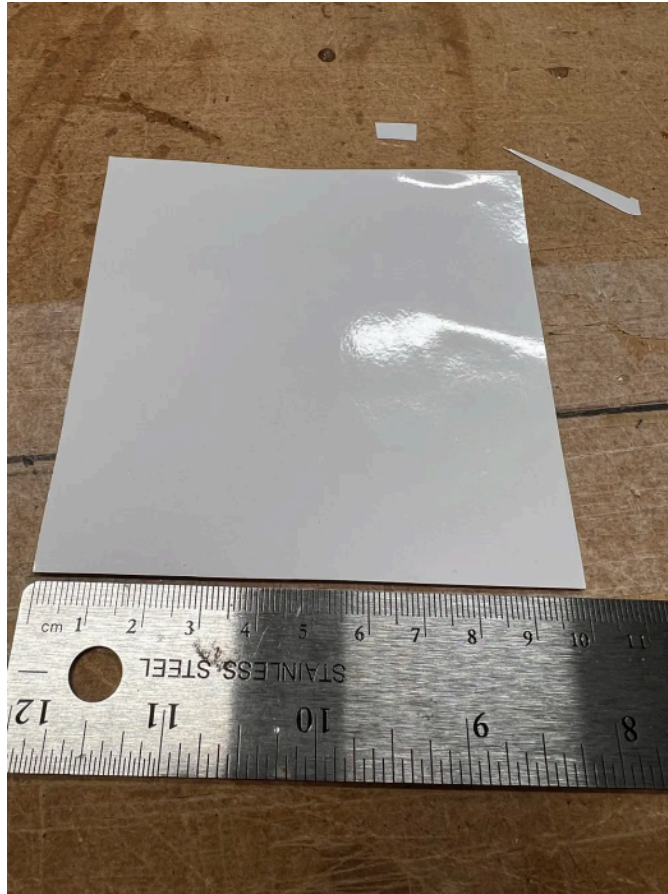



1dm² (100m x 100m) vinyl is 1.3g, that is 1.3g /dm². Note the diamond pattern in the adhesive.

The vinyl was cut to the rough shape of each wing panel and covering is the same process as normal methods: bottom first, then top, trim and overlap the edges. A non-contact heat source is used to activate the adhesive and 'set' the vinyl to the shape of the wing and can be used to stretch a little if you need it to take the form of something complex like a wing tip. Just be very careful not to over heat / rip the vinyl or to damage the foam underneath if using a heat gun as photographed. I prefer to use a hairdryer!



Cut to rough shape, warm and stick down. Trim with a sharp blade.



Ta-da! Wings covered.

Next up, the fuselage was covered in a blue vinyl giving a strong contrast versus the white wings and V-tail. The fuselage is a tricky shape to cover in a single piece, so I split the job into four steps: the two side panels followed by bottom and top. Seams and overlaps are there if you look closely, but take two steps back and they disappear.

Continuing with the theme and contrasting against the white, the ailerons were covered with the same blue.



Blue ailerons shown here temporarily hinged with masking tape.

Hinging the ailerons was done with glass repair tape. It's a flexible, strong, waterproof, and UV-resistant tape used to repair green house glass and available from most hardware stores or online. It comes in 50mm (2") wide rolls which is a bit too wide for most of my hinge needs. There's a couple of options to trim it down: I used to lay out the required length on baking parchment and then cut in half lengthways – 25mm (1") being ideal for most hinges. But now I have started cutting the whole roll in half, in-situ. A few minutes with a new and very sharp box cutter and you can split the roll. I found the parchment would sometimes leave a residue, didn't impact the adhesion, but it was visible under the tape once fitted.



Cutting down the tape on parchment paper.





Tape the 'inside' of the hinge first, then the 'top' / 'outside' of the hinge.

The Home Straight

We are nearly at the end, just the radio gear to deal with now! As mentioned, the *Rico-SHE* is a simple elevator and aileron glider. There are three servos to fit and wire – the elevator is a single servo operating a split push rod for each surface.



I'll be using my new FrSky Tandem x18.

I placed the servos on the top of the wing, operating the ailerons with a top hinge, allowing for a large upward operation if I want to experiment with spoileron braking while also keeping the upper surface of the airofoil a clean as possible – no large from a bottom hinged aileron junction.

The servos fit in their pockets snugly and are held in place with strapping (CW) tape that extends well beyond the edge of the pockets. It's then covered with vinyl for aesthetics. Their wires are run via a channel cut into the wing and then covered with vinyl. The wire tails are routed through the wing ready for connection in the fuselage.

Push rods and fittings were supplied in the box, but I elected to replace the servo ends with metal clevises. The plastic is used on the other end as 'servo savers' for those high energy arrivals we occasionally have. ✨ Wires were trimmed and terminated to avoid excess in the fuselage using my favourite tool: a cable crimp tool for servo connectors!

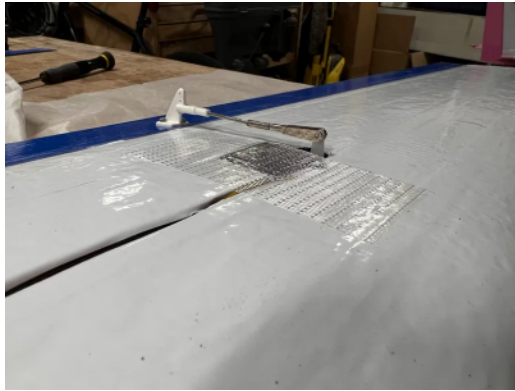

Servo fitted, control rods made, cables terminated.

The space is a little tight inside the fuselage! Originally, I used an FrSky G-RX8. This has been my 'go to' receiver (Rx) for years, what with eight channels and a built-in vario. However it's a little cramped once the battery and some foam is installed. FrSky has always had smaller Rx in their line up, but now that I have switched to a Tandem/EthOS transmitter (Tx), I can use the new Archer Rx too. Their new R4 Rx is ideal for this model: full range, four physical PWM channels – remember, I only have 3 servos! – and it's tiny, around half the length of the G-RX8.

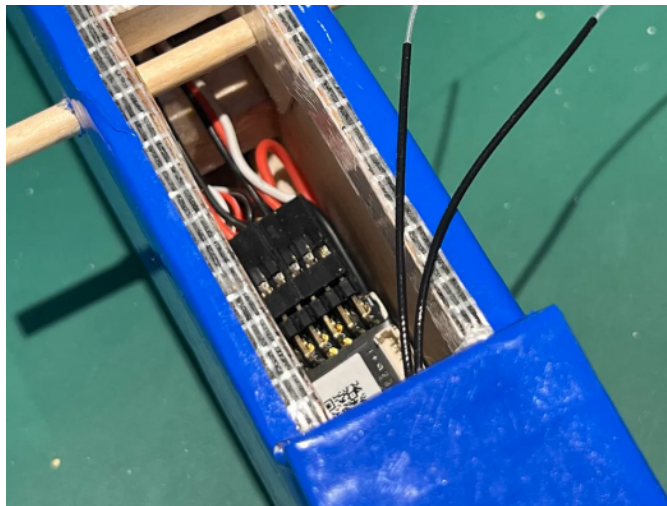
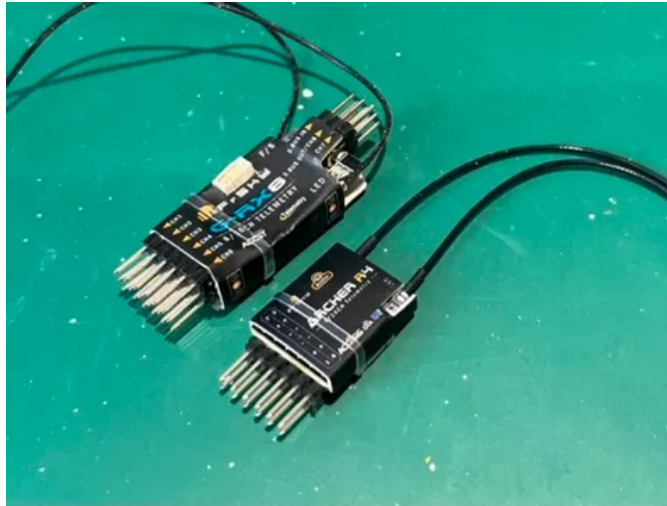

Maiden

After waiting what felt like weeks for a suitable weather window, the forecast suggested a showery day with suitable wind. Sure enough, the showers were there, but magically split round the hill, leaving us to enjoy a classic English autumn day with vivid greys, brilliant sunshine and plenty of mud. More about *that* later. The maiden flight was pretty uneventful, I picked a shallow hill to give me options, so didn't expect much in terms of soaring; more of an extended chuck test!



Maiden launch!





Sun, and a few more flights.

I Broke a Rib after The Maiden

“But the *Rico-SHE* hasn’t got any ribs!” I hear you say, and you’d be right! Humans do, however, and I broke a few of them about ten minutes after the maiden. Having done the flight and feeling confident about trim and CG, I decided to move to another part of the hill for some proper flights.

Remember the mud? The hill I was flying from is an ancient hill fort. The earth banks that formed the defences are still there – think moat which is to say a very large ditch. I had to cross the ditch to get to the other launch point. It was very muddy and I knew stopping part way down the slope would be impossible. I elected to start slowly and ‘go with it’ to the bottom.

Alas, near the end, my potential energy quickly converted to excess kinetic energy and I felt myself falling forward. I chucked the gliders in my hands to the side and *almost* got my hands out to cushion my fall. I landed square, chest first on the ‘up’ slope of the opposite bank, fortunately, avoiding the gliders.

In hind sight, it’s probably a good thing I didn’t get my arms out as I’d likely have broken a wrist or two. Severely winded, I stayed put for a good while recovering my breath and assessing things. I think a combination of adrenalin and cold masked things and I was able to walk around and fly for a couple more hours with some aches but not thinking much more about it. When I got back to the car however, I realised just how much pain I was in doing almost anything other than

standing upright. I'd broken a pair of lower ribs in the fall, my first glider related injury.



Iron age hill fort defences still working well in 2022.

Extra Credit

Following the successful maiden flights I decided to go a bit further with this build. I'd picked up some Mylar sheet for another project that didn't get used, so set about making some 'wipers' for the aileron hinges. This is a racer after all and has an RG15 section that is pretty flexible in speed range – more efficiency can only be a good thing right?

The aileron hinge gap is relatively large: ~2mm (1/10") opening to 5mm (3/16") when deflected up. Also, its full span, so plenty of benefit to be had. I've never made wipers before, but I thought I'd give it a go. I cut a rectangular section of Mylar, wide enough to attach to the wing and cover the gap when fully open. This is attached to the wing with tape and left free on the aileron side. Before fitting, the Mylar is given a gentle curve span wise to encourage it to follow the aerofoil. It's hard to see in the photos but it's there!

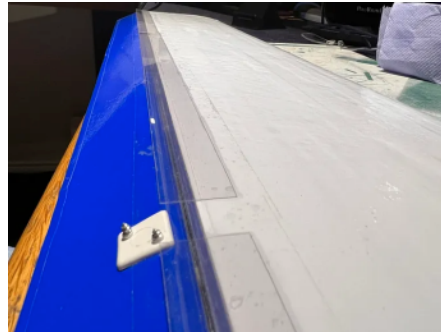
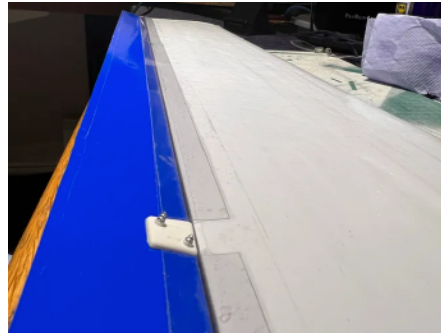
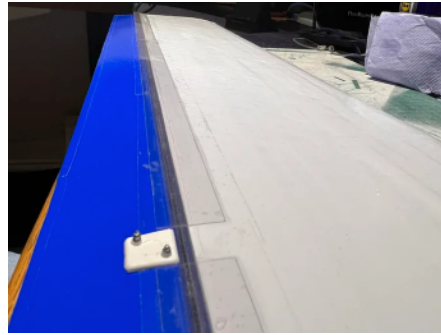

Aileron hinge gap (underside) – neutral, closed and open.

The final bit of extra credit was to sneak some decals through my wife's *Cricut* \3 vinyl cutting machine (link in *Resources*). I found some icon vector files online that sort of / kind of looked like a ball bouncing off a surface. With a bit of manipulation, the result, I hope, looks a bit like a ricochet. Add in some lettering and then 'print' in red for yet more contrast and the result is this distinctive pylon racer:





Component parts cut, initial alignment done, stripe and 'bounce' added.





Recently, the rain stopped for long enough for the sky to turn blue. I keep mentioning it, but it *really* has rained a *lot* here in the UK this winter! Light easterly winds were forecast ~8 mph so I made the trip to the hill with the *Supra* which can easily float around on that, but I also brought the *Rico-SHE* — just in case. Sure enough, there was plenty of lift and I decided to give the Rico a chuck. While not a speed daemon in the conditions, soaring was certainly possible and a few 30+ min flights achieved before the wind chill mandated a landing and warming of the hands.





A successful slope soaring session: Blue skies, two launched, 2 returned, no breakages!

If you have any questions please leave a comment below in the *Responses* sections. You get there by clicking the  below. I'll do my best to answer them. Thanks for reading!

©2023

Resources

- [Rico-SHE](#) from Phoenix Model Products. – “a stylish 60in EPP pylon racer and sports aerobatic sloper designed to meet the demand for more crash resistant pylon racers and conform to the new 60in EPP pylon racing class...”
- [Building Instructions](#) – The building instructions provided by Phoenix.
- [Metamark](#) – Sign materials and vinyl supplier.
- [Cricut 3](#) – “Cutting machines designed for home crafters. The machines are used for cutting paper, felt, vinyl, fabric...” (Wikipedia)
- [Meon Valley Soaring Association](#) – “A friendly club on the south coast of the UK. Access to the 2nd flight location is through membership of MVSA...”
- [Whittenham Clumps](#) on Wikipedia. – “A pair of chalk hills” near Oxford, UK. The location of the maiden flight, my broken ribs and a few other flights.
- [How Do I Know If I Have a Broken Rib?](#) – “The ribcage plays one of the most crucial roles in human anatomy ... it creates a shield that

protects hearts and lungs from trauma...”

All images by the author. Read the [next article](#) in this issue, return to the [previous article](#) in this issue or go to the [table of contents](#). A PDF version of this article, or the entire issue, is available [upon request](#).

Downsizing the Bergfalke IV



Losing altitude at White Sheet Hill – but not for long!

All-up weight without the 4S LiPo turned out to be 10lbs (4.5kg) which at first I thought a little high until I remembered that this was a two-seat glider, therefore larger than its single-seat brethren. I can't absolutely guarantee it, but should anyone prefer to do a standard version of this machine, then my original $\frac{1}{4}$ -scale *Bergfalke* canopy should be a reasonable fit. The overall size is one of comfort when it comes to self-launching, although I prefer to let one of the posse take over when the motor is running. Rigging is pretty quick and simple, although you do have to remember to fit the winglets! The Turnigy G32 motor gives plenty of urge via the 4S LiPo, despite the manufacturer's specs showing a max weight of 6lbs, but then, that's the efficiency of gliders for you. I don't think you can buy these motors any more, but the included specs in Part I ([link above](#)) last month should point the way to an alternative.

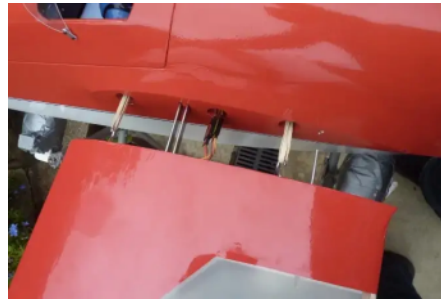
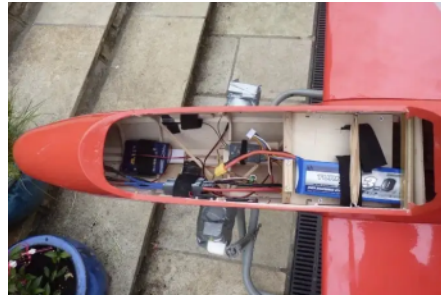

Left: View of the cockpit internals | Centre: Old-fashioned rubber band wing retention. | Right: The Smallpiece Super-Separator release evident on the underside of the fuselage. Click any image for more detail.

In flight the model is smooth and predictable, and at low speed is nice and safe, with plenty of warning of the approach of the stall. The brakes, in conjunction with up-lifting ailerons are very effective, allowing for precision slopeside landings when space is tight.





Left: Aerotow take off at Central Model Flying Club (CMFC). | Right: Motley Crew gives a manual launch at White Sheet Hill.

It has to be admitted that when light winds are in the forecast for expeditions to the slope, this *Bergfalke* is the one I reach for rather than the larger version for reasons of practicability, to the extent that to date it has flown mostly with the moustache.



Left: In Purist Mode at the White Sheet Hill. | Centre: Light winds at a White Sheet Hill Scale Fly-In event. | Right: Flying low at the Wessex Soaring Association's Stoney Down slope.

Should anyone fancy a go, the working drawings along with over 150 construction photos are available free-of-charge right here from the New RC Soaring Digest. See *Resources* below for the link.



Left: Mobius 4K cam view of aerotow launch at CMFC. | Right: Another Mobius 4K cam view of sunset flying session also at CMFC.

If you want to see the bird in action check out my *Baby Bergfalke IV* video on YouTube which is also linked below.



Author gives scale to 1:4.7 Bergfalke 4.

Thanks for reading and by all means, please let me know if you have any questions by leaving a comment in the *Responses* sections. You get there by clicking the  below.

©2023

Resources

- [Bergfalke IV Plans and Construction Photos](#) – Working drawings of the *Bergfalke IV* in PDF format along with over 150 construction photos.
- [The Williams Anthology](#) – The collected works of Chris Williams as found in the pages of the New RC Soaring Digest.
- [Baby Bergfalke IV](#) by the author on YouTube. – “Reduced scale version of the *Bergfalke IV*, given the fresh-air treatment and fitted with a moustache.”
- [Central Model Flying Club](#) – “welcomes all pilots of fixed wing, glider, and electric models to our Flying Club. Club field is situated in rural Shropshire, near to the Severn Valley Country Park and most types of models can be accommodated...”

- [Wessex Soaring Association](#) – “For 40 years the Wessex Soaring Association has been dedicated to the pursuit of all forms of radio controlled model gliding. With an impressive range of slope soaring sites to cover virtually all wind directions...”
- [White Sheet Hill](#) AKA *Whitesheet Hill* according to Wikipedia. – “a hill in the English county of Wiltshire. As one of the most westerly areas of downland in Britain the area is noted for its chalky farmland which contains a rich variety of rare and protected fauna and flora...”



The posse's total fleet of e-assist Bergfalke 4's. The 4.7:1-scale version is in the foreground while the quarter scale versions are in the background.

All images, tables and videos by the author. Read the [next article](#) in this issue, return to the [previous article](#) in this issue or go to the [table of contents](#). A PDF version of this article, or the entire issue, is available [upon request](#).

Dream 2700 | A Tailless Tale



The Dream 2700 flies!

Part IV: The Sky Awaits!

Those who have not yet done so may want to read the [first three parts](#) of this series before continuing with this article – Ed.

Finally, after a long journey, I was ready for the maiden flight. What a frightening day. I'm not a member at any model airfield right now. More than 30 years ago I was flying in the F3A category, and I was a very active pilot. In the last 20 years, I moved first to paragliding and after that to full-size sailplanes, and my scale model piloting skills went down a lot. I just flew F3K in the last ten years, because it was much simpler to carry this small sailplane with me, without all the hurdles and complications coming from more sophisticated models. My thumbs were shaking and, I must admit, I was tempted not to fly the model at all: after almost two years of effort, I didn't want to crash it.

*Feathers shall raise men even as they do birds, towards heaven;
that is by letters written with their quills. – Leonardo da Vinci*

At the same time, I wanted to prove my theoretical calculations, and some empirical assumptions were correct. And now I can confirm the quality of the design with pride!

There was no crash on the first flight, and the sailplane showed nice behaviour, without any bad habits.

Getting the center of gravity (CG) right is fundamental, especially on tailless airplanes, where a mistake can easily compromise the maiden flight. A CG too far aft can make the sailplane unstable, and a CG too far forward can make elevon authority vanish. All depends on your calculations or assumptions. I went for a conservative CG at 230mm from the leading edge at the root, corresponding to a 30% static margin.

| Initial Setup CG = 230mm W = 1680g | Deflection Angle ° | |
|--|---------------------------|-------------|
| | Up | Down |
| Elevons full | 15 | 10 |
| Elevons reduced | 12 | 7.5 |
| Ailerons full | 15 | 7.5 |
| Ailerons reduced | 12 | 5 |
| Flap thermal 1 | | 6 |
| Flaps thermal 2 | | 12 |
| Flaps landing | | 30 |

In a nutshell, the static margin represents the safety margin you have against the boundary situation where the CG lies exactly at the neutral point of the wing. Regarding control deflection angles, the limits were just based on my experience.

Round 1 Test Flights

Take Off

I was worried because of the wing loading (42g/dm²), therefore not so sure a hand launch was going to be okay. I've thought about a dolly or even a bungee launch. The dolly was not an option: due to the wing

sweep, the CG was falling a bit back after the wing root cord, requiring a specific dolly to be built. At the end I went for a hand launch, being confident that the static thrust (11.5N) was good enough to quickly accelerate the model. First lesson learned: fat fuselages are difficult to handle at full thrust! The risk of a premature release is there, with the fuse slipping out of your hand.



Last checks and first launch. Click any image for a more detailed view.

Climb

Just after releasing the *Dream 2700*, the plane looked very stable and controllable, the climb was extremely good – maybe too much at full throttle. As soon as the plane accelerated, the climb became steeper and steeper, up to the point where the trajectory became almost vertical. Second lesson: thrust line needs to be fixed. The propeller has a thrust angle of five degrees negative, and so the thrust line goes below the CG. I did it on purpose to reduce what I was expecting as a tendency to pitch down. Maybe I used too much. To fix it, there were two options: change the thrust angle – this would be the right way to do it, but it will require a modification of the firewall – or fix it

electronically, mixing the throttle with down elevons. This is a bit crazy: you solve one issue, but you generate more! Luckily for me, I went for the first option, adding an inclined spacer on the back of the firewall.

Cruise

After reducing power to 50%, the plane flew very well – like it was on rails. I did not observe any yaw or dutch roll tendencies at any speed. The speed looked good, around 10m/s (estimated), an indication the aerodesign was properly done. Elevons were responsive, only at low speed I see some authority issues. I did not see any pecking or high frequency pitch oscillations. This was observed previously on the SB-13 *Arcus* full-size sailplane (see *Resources*). The *Dream 2700* has a bigger sweep angle and much higher twist, that I think is making the difference.

Turns

And here is the most significant achievement: turns are coordinated with no tendency for adverse yaw. After roll banking, a small nose up input is needed to keep the altitude. Turn reversal, from +45 to -45 bank angle still needs to be evaluated: the behavior looks a bit slow and 'softy', but nothing to be really worried for a non-aerobatic sailplane. Barrel rolls are nice and easy. I cannot say the same for rolls on the axis: the design is simply not made for this.

Yaw stability is high. For sure this is connected to the fins' surface area. I'm sure I can reduce the fins size and surface, or even fly without them. This is a very interesting test I want to perform in the future. A tailless swept wing with a bell shaped lift distribution should not need fins at all.

Soaring

During the first flight, I forgot to program the engine brake function, and the propeller windmilled all the time during soaring. It's like having a drag chute attached to the tail! Nevertheless, the glide ratio

looks good. I tried to slow down, and the behavior still looked good, with a bit reduced elevon authority, but still with a very steady soaring path. The wingloading is quite high, but the plane shows some capabilities for thermal flight. Applying 6° flaps reduces the speed, but requires some elevon down-trim. To be further investigated is whether the CG position can be further optimized. I'm planning to install a GPS and a pitot tube, to better evaluate the glide performance.

Flaps

The initial setup of the flaps is in three positions: thermal (6°), low speed thermal (12°), and landing (30°).

Third lesson learned: thermal flap deflection needs to be much smaller than that. Even the 6° deflection is too much for efficient thermalling. You get higher lift, true, but you get as well a huge increase in drag.

The design intent was to have neutral flap behavior, as confirmed by XFLR5 simulations. Reality is a bit different, since flap deflection generates a pitch-up tendency. On a second prototype, I want to extend flaps towards the wing tips to correct this.

The first two flap positions are usable, with trim corrections. The landing position was unusable, due to a strong pitch-up tendency: the glider starts raising the nose, the speed goes down, and you easily get close to the stall incidence angle.

Minimum Speed

In a second flight, I tried to slow down as much as I could, acting only on elevons (no flap deflection). At full elevon deflection the plane starts stalling in a gentle way, recovering, and stalling again: not a bad behaviour. It reminds me of what I have read about Burt Rutan canard airplanes' stall. I didn't try any bank stalls for the time being. I got the feeling that control authority is not the best at low speeds: this needs to be further investigated. The small chord at the tips, coupled with low speed, produces very low Reynolds Number: this may lead to

think about flow separation, but this is not the case. At slow speeds, thanks to the high wing twist, the incidence angle at the tips is very low, and there should be no separation.

Round 2 Test Flights

After the first flights, I implemented the following changes:

- Air intake on the nose and exit on the tail, to improve motor cooling
- Removed 10g from the nose, moving CG to 233mm
- Reduced thrust angle to -1.6° (first flight was -5°)
- Heavily modified flap extension angles



Air intake at the nose, and exit at the tail, to improve motor cooling.

I'm happy to report that all the fine tuning and corrective action produced an improvement of the flight behaviour. With the reduced

thrust angle, hand-launch improved, making the plane less prone to nose-up. Cruise at 50% power improved as well, requiring almost no trim. Here are the revised flight parameters:

| Revised Setup | Deflection Angle ° | |
|--------------------------------------|--------------------|-------------|
| | Up | Down |
| CG = 233mm W = 1670g | | |
| Elevons full | 15 | 10 |
| Elevons reduced | 12 | 7.5 |
| Ailerons full | 15 | 7.5 |
| Ailerons reduced | 12 | 5 |
| Flap thermal 1 | | 2.5 |
| Flaps thermal 2 | | 5 |
| Flaps landing | | 17.5 |

A nice trial I did: I programmed one of the radio switches with circa 20% engine power. This is almost enough to counterbalance the *Dream 2700s* overall drag: this means that you can maintain altitude while consuming little battery energy, and even use very light winter thermals to climb a bit!

Flaps are now fully usable, even if I think I will further reduce the flap extension for the two thermal modes, moving from 2.5°/5° to 1.5°/3°. Landing position is now usable, even if it requires some down trim.

What Comes Next?

Despite being happy with the flight results, I'm already thinking about a second prototype with some more design changes:

- A more streamlined fuse, to minimize some of the issues highlighted by the CFD analysis
- Fins with reduced surface area
- Increase the elevon cord, and extension of the elevons up to the wingtips: this should increase control authority at low speed
- Increased wing section thickness at the wing root

Since flying performance is good, I'm now starting to think about making few items available for friends, but this requires a much quicker manufacturing process. I am tempted to go for full molds even if this becomes really expensive. Maybe the best compromise is to manufacture the mold of the fuselage, and continue to use the current vacuum forming on foam cores for the wings. And, whatever I decide to do with the molds, I definitely need to simplify the wing spar and joiner manufacturing process. Any suggestions from the community are more than welcome!

Wrap Up

Somebody once said "the journey is more important than the destination", and I now know that to be true!

Designing, building and flying your own creature — it's a transformation journey where you bring your ideas to life. It is as well an intensive learning process. It doesn't matter if the final product is perfect, what matters is the knowledge you acquire, and the personal satisfaction and pride you feel at each small step.

I would strongly suggest that experience to all of you, and it doesn't matter how complex your project is. What really matters is what you learn along the journey.

©2023

Resources

- [Dream 2700: A Flying Wing Design and Build](#) by the author on YouTube. — The collection of construction and flight videos about the author's *Dream 2700* project.
- [Akaflieg Braunschweig SB-13 Arcus](#) from Wikipedia. — "an experimental tailless, single seat, Standard Class glider designed and built in Germany in the early 1990s..."

All tables and images by the author. Read the [next article](#) in this issue, return to the [previous article](#) in this issue or go to the [table of contents](#). A PDF version of this article, or the entire issue, is available [upon request](#).

Project ALTius

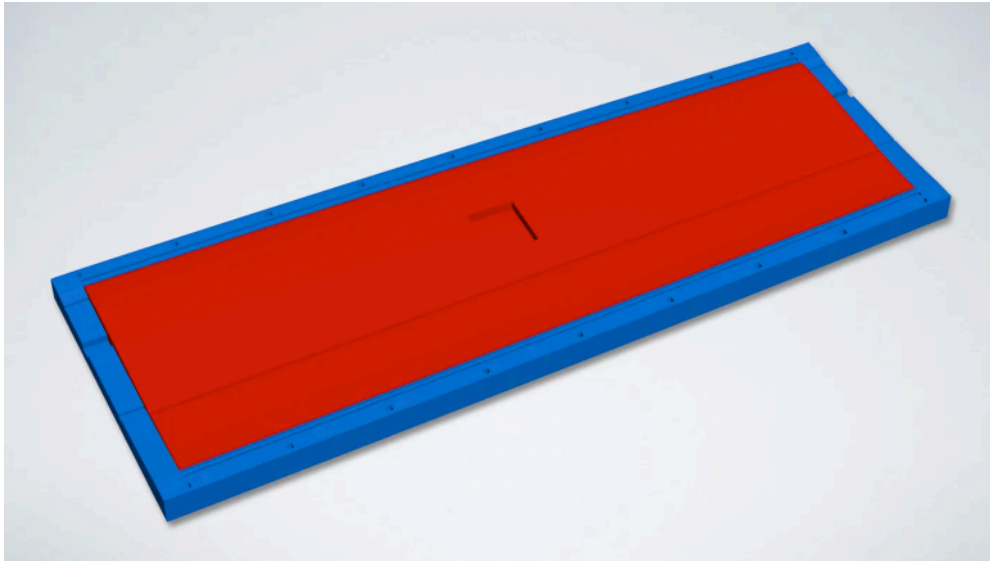

A wing segment shown in red with live hinge and servo indentations placed on top of the upper mold – in blue – with centering pins, resin trenches, protective walls and joiner/pins positioning.

Part I: A simpler approach to high-performance glider development using CAD/CAM.

We're delighted to announce a new contributor to the New RC Soaring Digest: Tiberiu Atudorei who is based in Ploiești, Romania. We've been hoping to find a series like the one Tiberiu kicks off this month – one that will walk through, step-by-step, the practical use of the modern tools of RC soaring design and development. Thanks, and welcome Tiberiu, we're all looking forward to your series. – Ed.

Once Upon a Time

Twenty-to-twenty-five years ago the world of RC gliders was dominated by Mark Drela's designs. If you have been in the hobby for more than ten years, you're likely familiar with airfoil series like the

AG25 and *AG35* and models like *Apogee*, *Allegro-Lite*, *Bubble Dancer* and *Supra*. Mark Drela's designs were likely the first 'open-source' gliders and in some cases employed *XFOIL* for their development. See *Resources* below for this and all relevant links for this article. For both balsa and composite designs Drela published airfoil data, building details, ribs and plans. Most designs used three airfoils – root, at the wing joiner and tips. He sometimes even used four airfoils. The designs were suitable to low-tech building methods: balsa ribs or foam cores cut between templates which, by the way, is maybe the best non-computational method to compute the transition between two airfoils.

Ten years ago there was a new generation of open-source glider designs by Gerald Taylor: *Zone*, *Zone2*, *Synergy*, *Synergy2* for F3H/DLG and *SynerJ* for F3J/F5J are a set of airfoils and wing designs usually published as *XFLR5* projects. Airfoils are thinner at 6–7% and the wing designs became more complex consisting of seven, eight or even nine airfoils. Free for both non-commercial **and** commercial use, they were very popular with high-end manufacturers who could afford the high cost of tooling design and production. There were also popular with the competition-oriented hobbyist who is often ready to pay for expensive models. With the DIY crowd, well, not so much. Why was that, exactly?

Now we have laser cutters, CNCs and 3D printers. Materials are quite cheap or at least affordable. We have free or cheap CAD software. Why is it so damn hard to build a performance glider? Why do we prefer the easy and cheap and convenient foam glider over a DIY low-tech balsa model or high-tech composite model? Why do we take pride in what we **buy** instead of what we **make**?

We Have the Tools

The simple answer is that we have tools such as *AutoCAD*, *QCAD*, *DraftSight*, *SolidWorks* and *Fusion 360* – for example – but these are quite hard to use. There is a lot to learning them and in some cases

the price is quite high in both time and money. Even if we know how to use them, these glider designs are quite complex projects. For those who say “it’s not rocket science”, I remind you our rocketeer friends don’t have to deal with eight, nine or even ten airfoils! For instance I’ll give you some details of the workflow for a simple balsa project and a more complex composite project:

Balsa/2D Workflow

Let’s consider a simple three airfoil Drela-type project – or even a seven-through-ten airfoil Taylor-type project, as candidly there is not much difference between how we handle them. We have as input a set of airfoil `.dat` files. These are basically a two column text file with X- and Y-axis normalised coordinates of the upper and lower profiles of the airfoil. In the best case scenario all sets of airfoil data have the same ‘cardinality’ – a fancy word to tell us that all sets of airfoils have the same number of points and in the same position on the X-axis.

How do we compute each intermediate airfoil? Using a spreadsheet, of course – any current one will do. First column: the positions in the X-axis. Second column: Y-axis values for the first airfoil. Third column: Y-axis values for second airfoil and so on. Let’s say that we have a transition for airfoil A to airfoil B over a distance of 50 cm and the balsa ribs are 5 cm spaced. You can compute the first rib as $90\%A+10\%B$ AKA as $0.9A+0.1B$, second rib as $0.8A+0.2B$ and so on. I’ll let you figure out how to adapt the formula if the $(\text{segment span})/(\text{rib distance})$ is not `10`.

Now the ‘hard work’ of computing intermediate airfoils is done all you have to do is save these numbers as a set of `.dat` files, use a tool to draw the airfoil (that is create a `.dxf` file), scale it, rotate it (don’t forget the washout!), add the main spar and maybe a secondary spar, consider control surfaces (spoilers, ailerons and flaps), compensate for D-box material, joiners, place it in the drawing in order to compensate for material consumption and – finally! – review the

design for cutting. Just a whole lot of 'fun' — and prone to errors. More like 'boring' if you ask me but then again, I've done it so many times.

Composite/3D Workflow

I'm afraid the situation is not very different. At least you don't need to compute the intermediate airfoils. You still need to scale the airfoils, rotate them, translate them in 3D XYZ coordinates to **exact** positions and then create surface or volume out of this set of polygons. I'm told this is called 'lofting'. Excuse my ignorance but *Fusion 360* or *SolidWorks* is not my cup of tea. I'm more of an *OpenSCAD* person. And of course you have to deal with the control surfaces and hinges. And servo pockets. And spars and joiners. And plugs and molds. Yes, never ending 'fun' time. And after all this hard work it will still look like a hatchet job or — in case we use some fancy curves for shaping the wing — it will have a different aerodynamic behaviour compared to what the designer had in mind. And if you have just a small adjustment in data input—say, the airfoil set or the wingspan or chord or a 'big flaps' variant— you can trash all your work and start over.

Making You SAD with a Little HAM on The Side

If we look closer to both these workflows we see that they both involve dealing with a large set of numbers — the `.dat` files — the changes are similar — scale, translate and/or rotate — and quite repetitive. All these operations can be automated in a program or application. You give as input the wing definition — the set of `.dat` file and the distribution of airfoils — and some building parameters — wingspan, central chord, position of control surfaces, type of construction, materials used and so on — and the program does the rest. It creates a `.dxf` file with the set of ribs which are (almost) ready to be laser cut. Or a set of 3D model files (`.stl` files) you can 3D print or machine on a CNC. If you think of CAD and CAM programs

are 'tools' then this is like a 'pre-tool'. It's definitely like CAD but a little bit different. CAD/CAM are general use tools, while these are very specialized to the task at hand. We can call them, say Program Assisted Design (PAD) or maybe Application Assisted Design (AAD). But I'll use Software Assisted Design or, you guessed it, SAD.

If you are the buy-and-fly/crash type probably this article and subsequent parts are not for you. But if you are the dream-design-build-fly-crash-fix-repeat type I will try to help you with the design-build part. To give you the software tools described above but also the hardware tools. This is another great acronym: HAM for Hardware Assisted Manufacturing. Don't worry, it's just a term for DIY laser cutters and 3D resin printers.

Basic SAD Workflow

It's actually quite simple in structure. SAD apps read some `.dat` files – defining the airfoils used in the wing, a wing definition file – often just plain direct exports from the *XFLR5* project – and a file for parameters and options. Some number crunching for interpolation, scaling, translation and rotation operations and we have a large set of 3D coordinates describing the wing. The next step is to write the output file(s): both are in ASCII text form: either `.dxf` or `.stl`. This looks complicated but it's not – it's just drawing a line or circle for `.dxf` or a vertex for 3D `.stl`. Don't expect a fancy user interface: these are very simple, text-based, command line interface (CLI) apps.

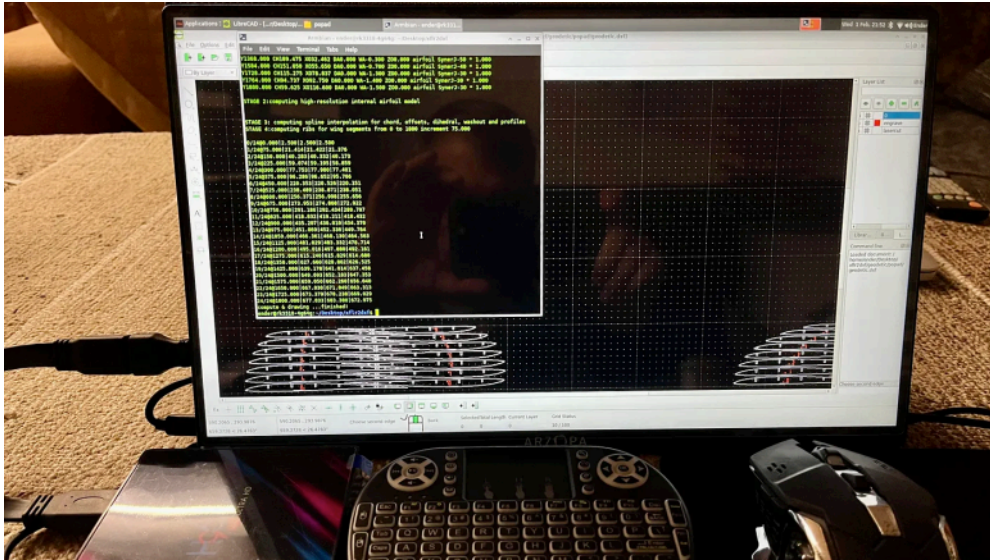

No fancy UI, but it works: computing geodetic ribs running on a USD\$30–40 Android TV box re-installed with Linux. The text-based app is running on a terminal window on top of LibreCAD displaying the result.

As long as your platform has a C compiler you're fine: you can run them in Windows, MacOS, Linux or even Linux/ARM. And with no big difference except in compute times: you get the same output in a recent Windows laptop — in two-to-three seconds for a drawing or two-to-three minutes for a full set of 3D models. In a *Raspberry Pi* or similar it will take seven-to-eight minutes for a 3D model file. Actually, all the computation phase is done in a couple of seconds, most time is spent in writing the files.

Some Examples

Exhibits A1 and A2 are an example of SAD 2D: a simple application for drawing the elements, in this case the ribs, of a Drela — type three airfoil wing. Note that for all of the examples shown below you can click on the image to see it in *much* higher resolution.

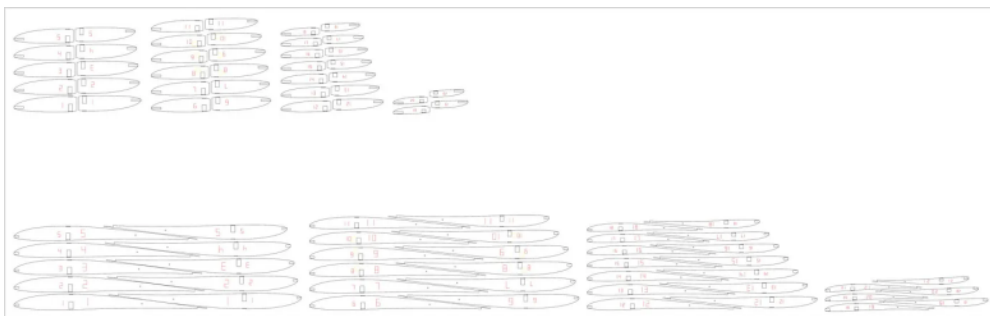
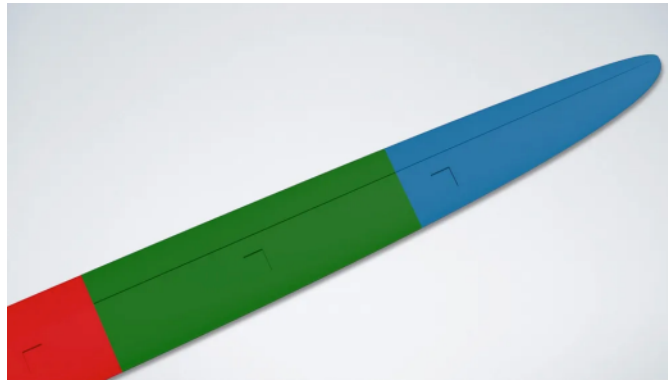

Exhibit A1 (5.5MB)



Exhibit A2 (3.4MB)

Exhibits B and C are examples of SAD 3D: a couple of apps to help you design an F5J fuselage and wing consisting of 3D models for wing segments, surfaces, molds and plugs. It's a complex wing model, a Taylor-type F3J/F5J *SynerJ*-like project.



Left: Exhibit B. | Right: Exhibit C. Click either for a closer look.

And finally, for this month at least, Exhibit D is an example SAD 2.5D: an app for drawing normal and geodetic balsa ribs for the wing shown in Exhibit C in case you want to have a geodetic balsa construction or, even better, a composite hollow wing with geodetic rib reinforcements.

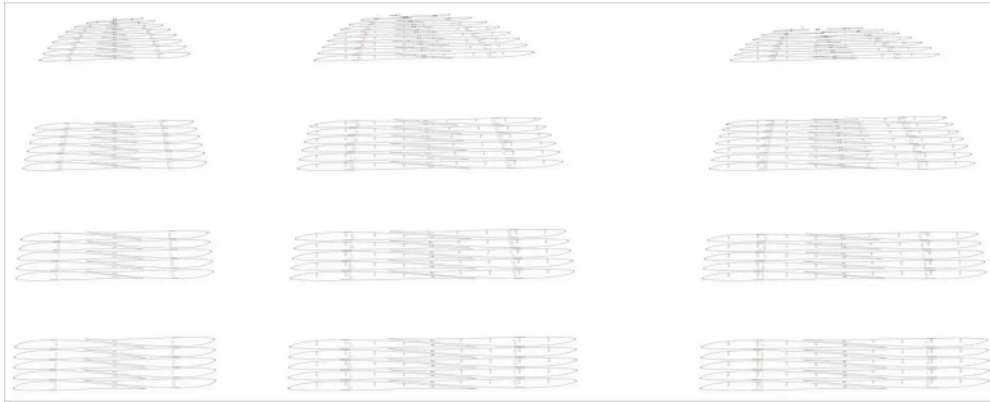



Exhibit D (8.5MB)

If you are interested in these SAD little apps and you think you can use some help in your projects: please don't hesitate add your comments and questions below in the *Responses* section, which you can find by clicking the little  below. Please let me know if you are interested in balsa or composite or perhaps some unorthodox methods – composite hollow wings reinforced with geodetic balsa ribs or maybe 3D printed wings?

For the moment I'd recommend to get familiar with the *ALTi* project from the RCGroups build log (link also in *Resources*) so there is no need to repeat what's there. I'll just post some updates in the next issues and focus more on practical parts and other apps.

Thanks for reading and see you next month!

©2023

Personal footnote: I'm dedicating this series in two ways both of which are of great importance to me: to Viktor Frunze of Krasnodar, Russia and noted F3K and F5J designer, builder and competitor who passed away recently and, equally, to the people of Ukraine.

Resources

- [AutoCAD](#) – “2D and 3D CAD software trusted by millions to draft, engineer, and automate designs anywhere, anytime...”

The Hustler

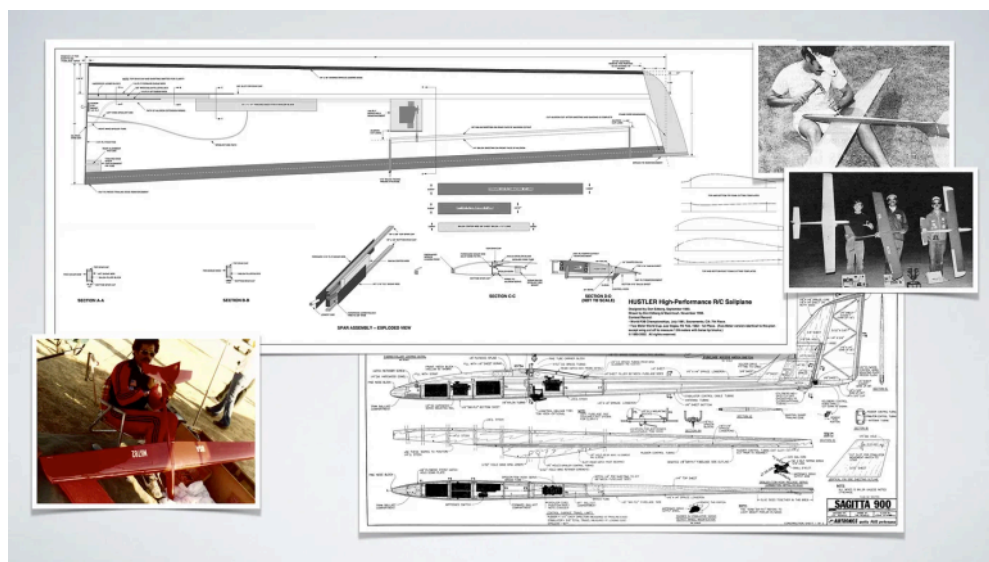

The Hustler in drawings and pictures. (credit: Don Edberg, Bill Forrey, Lee Renaud)

Your opportunity to build a classic design from the golden age of RC sailplanes.

*Call it 'retro fever' – designs from 1970s, 1980s and 1990s are amongst the most popular that we publish in the New RC Soaring Digest. We're delighted to be able to present another in this series with a previously **unpublished** construction article and drawings from RC soaring legend Don Edberg. These were originally authored in 2002. – Ed.*

Recently there has been an increase in popularity of aileron-controlled 'flat-winged' sailplanes. These are models with dihedral and ailerons, as opposed to polyhedral models that use rudder control. There are many reasons for this popularity, among them better performance in windy conditions, more maneuverability, higher speed range, and simply that they are more fun to fly. You might consider an aileron model as a sports car compared to a poly model as a commuter car.

This construction article is about how you can quickly and cheaply build a high-performance aileron ship by building a new set of wings to be used with the fuselage of an already existing Airtronics *Sagitta 900*. The *Sagitta* appeared in the April 1981 edition of RC Modeler, and a plan set (#831) is available from the plans service. (See Resources below for a current link to *Sagitta* plans found on Outerzone. – Ed.) Instead of spending \$200 or more for a commercial kit such as a *Falcon* or *Saber* AND \$200 more for wing servos, you can build a new set of wings very inexpensively and need just two aileron servos. The *Sagitta 900* fuselage and tail can be used with minimal changes.

The *Hustler's* wings are foam-core, with very simple and tough spar construction, and a balsa skin applied with transfer tape. The wings can be built by anyone having the skills to build the *Sagitta 900*, in a much shorter time period. In fact, if you have a *Sagitta 900* kit available, only a few parts need be made – the rest are already in the kit. The airfoil on the prototypes was the Eppler 205.

The *Hustler* is not a new design. In fact, the first prototype was built in November of 1980 as a test model for the author, who was a member of the 1981 US F3B World Championships team. It was an evolution of the 'straight-winged' modification of a *Sagitta 900* used to make the 1981 United States F3B team earlier that year. (That wing took a long time to fabricate because of its built-up construction, because it was essentially a fully sheeted *Sagitta* wing with no polyhedral, and ailerons added.) It was felt that a foam-core version would be faster and easier to build, as well as better aerodynamically. Thus the *Hustler* was born.

A careful comparison with the *Sagitta 900* will show that the wingspan is the same. However, the *Hustler* features a single-taper wing rather than a constant chord section attached to a tapered tip section. This planform is much easier to build, and does not compromise aerodynamic performance. The wing features a spar construction similar to the *Sagitta*, yet beefed up for the hard zoom

launches that are popular these days. In fact, the *Hustler* has withstood launches from a long-ago banned 24-volt electric winch!

Hustler only uses a touch of composite materials, and no special skill is needed for their application. The wing is sheeted with 1/16" (1.5mm) balsa sheeting using transfer tape, and may be either covered with plastic film or 'microglass', 0.6 oz/yd² (20g/m²) fiberglass. The latter is more work but adds stiffness.

The *Hustler*, as mentioned earlier, is a 'full-house' model, featuring two independent ailerons, elevator, rudder, and spoilers. Flaps are not used to follow the KISS philosophy ("Keep It Simple, Silly") and to save the cost of two additional servos. Instead, the glide path control is achieved by spoilers activated like the *Sagitta's*. *Hustler* is set up so that the advanced computer radios are unnecessary, which can save additional money for those who would like to try multitask airplanes without buying a computer radio (they were unavailable in 1980 in any case!) The only unusual feature is that there is one servo for each aileron. This makes the linkages trivial – just a short rod from the servo to the aileron control horn – and eliminates control linkages and mechanical hookups with the fuselage. Only two spoiler cables and two aileron connectors need to be hooked up before flying.

You may be asking how well this model flies. After flying the prototype *Hustler*, I was so enthusiastic about its performance that I built three additional models. In the F3B World Championships that were held in Sacramento during July of 1980, I placed 7th out of some 50 contestants – not bad for an all balsa and foam model constructed in a garage!

After the World Champs, I eventually sold three of the four *Hustlers*, but I still have one that I regularly fly. This means that the construction has shown its mettle by surviving over 21 years of hard usage! That same model has shown its utility by being competitive in the RCM Trophy Race (now called the International Slope Race), and by placing and winning in many regional northern and southern California slope, thermal, and multitask contests. After its wings were shortened to

two meters wingspan, it won the 1982 Two Meter World Cup contest held in Las Vegas.

If you already have a *Sagitta 900* and you'd like to try multitask sailplanes without buying a \$500 computer radio, a \$200 model kit, and \$200 more for wing servos, the *Hustler* should be a worthwhile project to you! Read these simple assembly instructions and you will soon be ready to start your own *Hustler*!

Construction Procedure

Step 1

Plug one end of the large brass wing joiner tube with a scrap of balsa. Be sure that it is airtight so epoxy won't leak inside during the next step.

Step 2

Use a coarse file or sandpaper to roughen the outside of the brass tube, and clean off your finger oils with acetone or alcohol. Mix a batch of slow-cure epoxy with microballoons to make a putty-like consistency. Put some in the slot of the joiner block where the tube is located. Put the tube into position, being careful to fill all open areas and get rid of bubbles. **Make sure that you have the open end of the brass tube sticking out the correct end of the blocks.** Let the epoxy cure before you cut the width of the hardwood block down to 3/8". (If you are working with a *Sagitta 900* kit, you will also need to trim off 3/32" from the bottom of the hardwood block that holds the brass tube. Be careful to make a right and a left set.) Both of these operations are best done with a Dremel table saw. (For the *Sagitta* kit, you will also need to splice the eight spar caps to make four, 48" long pieces. I usually use a long diagonal cut and glue the cut edges together. A 1.5" to 2" long diagonal cut will work fine.)

Step 3

Taper, if necessary, the two pairs of shear webs to accommodate the slight change in thickness along the wing spar. Use a straight pin to make holes in the outer faces of the hardwood block, which will make the glue joint much stronger by increasing the bond area. Also make holes in the mating portions of the plywood shear webs. Don't get too carried away – just a few holes will increase the glue area.

Separate the parts of the spars into two sets, one for the left spar and one for the right. Use a red felt pen to color the inside face of the hardwood block (that is, the face that the brass tube sticks out of), and the two shear webs. Plan to assemble one spar at a time, one right and one left. The right spar, with the felt pen visible on its root, will look like the one on the plans, while the left will be its mirror image. The longer plywood web is on the front of both spar assemblies.

Now you are ready to assemble the spars. Steps 4 and 5 should be done without interruption.

Step 4

The entire spars will be assembled and allowed to dry, then later joined to the wing. This ensures a strong spar assembly. Mix a batch of epoxy and coat the rear face of the forward plywood shear web, the front face of the aft ply shear web, all faces of the balsa filler block (except half of the rear area). **Do not use** five-minute epoxy for this step!! Place the hardwood block and the balsa block onto the rear of the forward shear web (be sure that the **open** end of the tube is towards the outside), and then sandwich them underneath the aft shear web.

Step 5

Coat the spruce spar caps with epoxy 9" out on one wide surface. Put these spar caps into the spaces between the front and rear ply webs. Make sure that the balsa block is pushed hard against the end of the hardwood joiner block, and that everything fits tightly. With epoxy oozing out of everything, it's a mess, but you're almost done. Get a bunch of rubber bands and wrap them around all the glued areas. You can also use a bunch of steel 'paper clamps' to clamp it all together. Set the spar assemblies aside to cure.

Step 6

While the spar assemblies are curing, you can start preparation of the foam cores. Your reference in this regard is *Foam Wings*, by J. Alexander, RCM Anthology Library Series. (*We have tracked down a current source for this book and noted in Resources, below. – Ed.*)

For protection, I like to glue on the leading edge (LE) piece first. You can use either water-based aliphatic resin or User-Friendly Odorless (UFO), the foam-compatible Cyanoacrylate (CA). The former allows more time to get the wood in the proper location. (If you are using a *Sagitta* kit, you should splice the two short leading edge pieces together with a piece of spruce or ply. You will have to notch the core to fit the splice piece.) Use masking tape to hold the LE in its proper orientation.

Step 7

Now is the time to cut spar notches in the foam core. You will need a 48" straightedge and a Dremel tool with a router attachment and bit. Carefully measure and mark the location of the front and rear of the spars on both the root and tip of the core, then connect with full span marks. Pilot *Razor Point* pens work well for this application. Then, tape the straightedge into a position so that it will cut right to one of the marks. Use the Dremel to make a slot that is exactly 1/8" (3mm) deep. A scrap of 1/8" balsa is handy for this purpose. The bits are normally not wide enough to make the 3/8" cut in a single pass, so

you will have to repeat after moving the straightedge. This will make a mess with little bits of Styrofoam but is easy to clean up with a vacuum cleaner. Check the fit with a piece of 1/8" x 3/8" spruce – it should be snug, not loose or tight. You can make a simple tool to sand the groove with a piece of 120–150 grit sandpaper glued to a piece of 1/8 x 3/8, in turn glued onto a 12" long block.

Step 8

Now repeat this procedure on the bottom of the cores. **It is critically important that the locations of the spars coincide, especially at the root.** Be very careful in your measuring.

Step 9

Once the spar slots are cut, you will need to remove additional foam where the plywood shear webs and balsa filler block are located. For details, see sections A-A, B-B, and C-C on the plans. This can be done with an X-acto knife with a sharp blade or a hacksaw blade, but be careful either way. You might want to just sand it in, which takes longer but is safer. Final fitting will occur after the spar assemblies have cured.

Step 10

Use the Dremel to cut the tracks for the spoiler tubes. Notice that the right wing and left wing are slightly different, so that the cables will connect to the proper ends of the servo arm. The tubes may be installed with five-minute epoxy or UFO. Leave the portion near the roots loose so that they can easily be fit into the root ribs later. A scrap of balsa supports the end of the tube near the spoiler. Be sure that the tube hole is deep enough at this location (consult with the *Sagitta* plans for more information). Also check that the tube is more than 1/8" deep where it crosses the aileron wire.

Step 11

You may now cut the aileron wire slots with the Dremel. These can stay just 1/8" deep and the wire will be flush with the bottom of the core. Make two sets of wire by twisting together three insulated conductors of 24 to 26 gauge insulated wire. I recommend black for ground, red for positive, and white or orange for signal. You can glue these wires into position, but they only need to be tack glued, because there are no loads on them.

Step 12

Trial fit each spar assembly in each corresponding wing. If necessary, sand or cut off more foam so that the fit is snug. Check the spar assembly fits snugly within the wing cutout. If the slots are too narrow, the foam may try to expand away from the spar assemblies.

Step 12.5

The original *Hustlers* had the shear web/spar cap box simply glued together around the joiner tube. If you are concerned about the strength of your joints, you might want to wrap the first two or three inches with carpet thread or better yet, Kevlar® tow or threads. Use CA and be sure to wrap at least the root of the wing, if you do it.

Step 13

Now comes the fun. It is time to glue the spar assembly into the foam core. I used Titebond aliphatic resin on all of my *Hustler* wings, because it seems to seep in between the beads of the foam core and stick very well. (You may want to try Hot Stuff's UFO thick CA glue, but I am not sure that there would be enough time and have never tried it.) Apply a generous amount of glue to the front and back of the spar assembly, as well as to the spar cap slots in the core. Gently spread the two caps and slide the spar assembly onto the core. It should

move so that the end of the spar is about 1/8" inside of the foam. Use masking tape on both sides to hold the core firmly against the spar at the root. Lay some waxed paper along the inside of the top core bed where the spar is now oozing glue. Place the core/spar inverted into the bed, then place a second piece of waxed paper over the bottom spar. Finally, place the bottom core bed on top of the whole assembly. When you are sure that the cores are properly set in the beds and all parts are properly positioned, place weights on the assembly. I use piles of five or six hardbound books over the entire span of the wing (we're talking about a library here, 30 or 40 books altogether). I have also used winch batteries. You will want to leave this undisturbed 24–48 hours for the aliphatic resin to dry out totally.

Step 14

After at least 24 hours (with aliphatic resins, less with epoxies), you can open up and look. Now measure the location of the rear alignment pin tubes, and cut a slot to hold them near the root. Glue them in using as little glue as possible.

Step 15

Fit the wing onto your fuselage and joiner rod. If you don't have a fuselage, you'll have to get it built before you can continue!! Carefully trim the root of the wing to make it parallel to the fuselage. Drill two 1/8" diameter holes in the fuselage sides positioned to receive and clear the aileron wires and the spoiler tubes. If the brass joiner tube sticks out too far, you may need to file it down. Remember that the root rib is 1/16" (1.5mm) thick, so leave at least that much tube sticking out the spar assembly. **It is very important that the brass tube pass through and is bonded to the root rib.**

Step 16

The root rib fits onto the root of the wing and is butt-jointed with the sheeting. Remove enough foam so that it fits in well between the wing spar and the fuselage. Glue on the 1/8" ply screw eye mount to take the root screw eye, and drill a matching hole in the foam to clear.

Step 17

Now glue on the root rib. Be sure that both the spoiler tube and the aileron wires are protruding through the holes in the proper location. Use five-minute epoxy and microballoons and fill all the space between the rib, core, and sheeting. Be careful to keep epoxy away from the aileron servo wires.

Step 18

Measure and carefully cut out the aileron servo bay foam, but try to cut in one piece so you can replace it back in the hole so that the sheeting can be put on without caving in. Draw a big on the top and bottom to indicate where to avoid putting transfer tape, as this piece will be removed after the wing is sheeted.

Step 19

Measure and carefully cut out the spoiler bay with a sharp X-acto knife. Remember to cut the same shape as the spoiler blade. There will be 1/16" sheeting covering the top, so don't dig down too deep.

Step 20

Take a look at the wing for dents, slots, and other boo-boos. All of these can be filled with the lightweight spackling compound. After the compound dries, sand it gently. Bumps should be avoided because they will show somewhat through the wing surface, but this is the beauty of balsa sheeting — the bumps may be sanded out. Vacuum bagging with fiberglass does not have this luxury.

Step 21

Apply fiberglass tape in a geodetic pattern on the top and bottom surfaces of the wing core, as shown on the plans. Try to avoid the areas of the spoiler bay and the aileron hatch. Be sure that the tape is stuck down well.

Step 22

Join the balsa sheeting pieces for the wing skins. I use thin CA and sand the joints afterwards. If you are careful you can make all four skins out of 10 pieces of 1/16" x 3" x 48" balsa sheeting. I usually try to have the grain parallel to the wing leading edge. Leave the sheeting oversize so that it doesn't have to be positioned perfectly on the wing.

Step 23

Apply transfer tape to the bottom of the wing. Avoid placing any over the wing spar or the aileron hatch. Put down two layers at the leading edge and the locations just in front of and just behind the spar, as well as at the root and tip of the wing.

Steps 24–30 should be done consecutively, without taking a break, so have about three hours of nonstop time available.

Step 24

Peel off the protective covering from the transfer tape. Squeeze out a bead of your favorite adhesive onto the top of the spar. Now, with the wing core bottom-side up in the bed, carefully position the sheeting just above. It may be worth having a friend to help to be sure the entire area is covered, because once the wood is down, it sticks!

Step 25

Double check to see that the core is in its bed. Now press down the sheeting, starting from the point of first contact outwards. Once contact is made everywhere, use a cloth to rub everything down fairly hard as if you were polishing a car.

Step 26

Turn the wing so its top surface is upwards, and mark the two ends of the spoiler cutout on both the leading edge hardwood and trailing edge (TE) balsa, so that it may be found after the top is sheeted.

Step 27

Bevel the bottom piece of sheeting so that it comes to a sharp edge. Glue the 1/64" plywood trailing edge reinforcement onto the balsa and the top of the foam where it overlaps. Be sure the wing is on a flat surface to prevent warping of the TE.

Step 28

Check for any dents or dings, and fill as necessary. Make a masking tape 'hinge' on the trailing edge wood piece bottom, so that the top piece may be just folded over to the correct position. Apply transfer tape to the top, using double layers at the leading edge (just after wood ends), before and after spar cap, root, and foam trailing edge.

Step 29

Peel off the backing of all transfer tape. Apply a bead of glue to the top of the spar and to the plywood trailing edge reinforcement.

Step 30

Now simply fold over the top sheeting, being careful not to pull the masking tape hinge loose. Press down all over, rubbing down with a

cloth. Be careful not to crush the sheeting near the spoiler cutout. When all done, place the top bed over the wing, and put as many books or weights on top of the entire surface as possible. An alternate scheme is to use a vacuum bag, but a word to the wise: 1 lb foam crushes at about 4 psi or 8" of mercury, so use **very little** vacuum or you will ruin the wings. The transfer tape achieves something like 60% of its strength after 24 hours, so let it sit overnight. Repeat with other wing panel.

Step 31

After setting, look at your handiwork! You should trim the leading and trailing edge sheeting, as well as root and tip. You should use a layer of CA to glue the sheeting onto the leading edge hardwood. Glue on the balsa tip.

Step 32

Now carve the tip block to shape, and sand the leading edge to its final shape. Locate the two marks on each end of the spoiler bay, and the rear of the spar cap. Carefully remove the spoiler bay balsa sheet and fit the balsa spoiler blade (trailing edge piece) inside. You may need to take out more foam. If you remove too much, just glue in some balsa sheet spacers. Clear the foam away from the end of the spoiler tube.

Step 33

Lay pieces of 1/16" balsa on the sides and 1/64" ply on the inside of the sheeting of the aileron servo bay. Add your favorite method of holding the servo in place. If you use the Airtronics 94141, you can glue in blocks and simply bolt it into position. With other servos, you can make blocks that the servo slides into, and use a tiny drop of CA to secure into position.

Step 34

Now it's time for a final sanding before covering. Start with 220 and work your way up to at least 400 grit sandpaper. Try to smooth out all balsa sheeting joints, and the tip blocks. Sand the trailing edge down to the plywood reinforcement, making a knife edge. Fill any dents with putty.

Step 35

This will hurt, but you have to cut up your nice wing now! Cut out the aileron with an X-acto knife or sharp razor saw. Make sure the cuts are in the right position. Glue the balsa pieces onto all exposed foam. Bevel the front of the ailerons to the 20 degree angle, if you do not have the already beveled pieces. This may be done easily with a Dremel saw set to the proper angle, since the ailerons are constant chord.

Step 36

Cover the wing with your favorite covering material. Be sure that it is well stuck down at the leading edge of the ailerons and the trailing edge of the aileron cutout. This is because we will use either tape or covering material as a hinge, and we don't want the covering to come loose!

Step 37

Now you may attach the aileron to the wing. Use cardboard or paper shims to center the aileron in its cutout. Hold it in its full down position, and carefully tack down the covering material. You can do this at a light heat setting with some materials that will allow you to pull it up if something is wrong. When you are satisfied with the fit and the movement, iron down the entire joined surface. Put some 'holder' covering material pieces on the back side of the hinge – one at each

end of the aileron, and one at the hinge near the location of the servo pushrod.

Step 38

Cut out the covering over the spoiler bay. Do a final fit on the spoiler before covering it (be sure to allow for the thickness of the covering material). You may now hinge the spoiler similar to the aileron. Next, secure the spoiler horn using CA. Cut out enough foam between the spars for the horn to fit in between. Next, bend up a straight pin as shown on the plans (?) and attach it to the spoiler blade with CA. Fabricate an anchor for the spring and glue it to the top face of the bottom spar cap. Connect the return spring to the two locations. Put the dial cord through the tube and secure to the horn with a toothpick wedged into the hole. If you follow the plans carefully, you will have a spoiler that opens easily but retracts positively.

Step 39

Fit the wing onto the fuselage and use a long 3/32" drill passing through the body to cut a hole into the alignment pin holder wood. Remove the wing and very carefully drill out the hole to 1/8" diameter. Glue the alignment tube into position, using 5 minute epoxy. Slide the wing into position while wet to make sure that the alignment is OK. Repeat with the other wing, being sure that the wings are both at the same incidence.

Step 40

Now terminate the aileron servo wires at the root of the wing. You can either make holes and manually plug them into a 'y' connector, or you can make plugs for automatic hookup as shown in the *Soaring* column, November 1989 RCM (p. 51). I recommend the latter because it will not wear down the wires nearly as much.

Step 41

When you are able, neutralize each aileron servo. Attach an arm to the servos, rotated towards the leading edge about 15–20 degrees. This mechanically provides differential (more up throw than down). If you have a computer radio you can leave the arm perpendicular to the wing surface and set differential mechanically. Make a plywood horn, and glue it to the leading edge of the aileron, or use a commercial plastic horn and embed it within the aileron. Be sure that the horn is mounted securely, or flutter may be a problem. Now make a pushrod by installing a threaded clevis onto one end of a threaded rod, then soldering a clevis onto the other end. You want to make sure that the threaded clevis is located in the middle of its adjustment range when both the servo and aileron are in neutral.

Sagitta Fuselage Modifications

Step 1

You will need to install a 'y' connector, or the appropriate wiring if you have built-in connectors. I ended up making clearance holes in the fuselage sides so that the wing connectors could go through and plug in. Later, I came up with the automatic plug-in mentioned earlier.

Step 2

Plug the wings in, plug in the aileron connectors, and see that the ailerons move in the right direction. (Right turn: right aileron goes up, left one goes down). You may want to add rudder coupling for now, but it is best to learn to use the rudder separately. Since ailerons are your primary turning function, I put them on the right-hand stick (Mode 2) and rudder on the left stick.

Step 3

Check to see that both spoilers open at the same time, and close without sticking. Free up any locations that rub.

Step 4 (optional)

We would suggest removing the counterbalance on the rudder, and gluing it onto the fin. Otherwise, at high speeds, there can be a 'waddle' that looks bad and slows down the model.

Step 5

That's all you need to do, except to be sure that the center of gravity is located in the proper location (about 3.8" back from the leading edge). Remember, this new *Hustler* wing may have a different CG than the older kit wing.

Flying Technique

Pages could be written about flying techniques, but I will try to boil it down into a few important points.

First, you have to recognize that the *Hustler* is not intended to be a floater. It has high performance but needs to be flown a little differently to achieve it. Be sure that you maintain flying speed at all times, especially thermalling. When thermalling, be sure that the fuselage is more or less level on the horizon, and maintain flying speed. Usually you can use ailerons to bank into a turn, then hold only rudder or some opposite ailerons to keep from spiraling inwards. It is definitely different from flying a poly ship but once you get used to it, you will enjoy it! You will find that the ease of re-centering and changing direction makes an aileron ship a joy to fly.

You will find that the *Hustler* covers ground very well, and in winds you can easily penetrate upwind to a wave, or thermal downwind and cruise back to the landing area from a great distance. You will need to

pay a little more attention to your flying because the aileron-winged ships are not quite as stable.

Launching and landing are similar to the *Sagitta*, except that for launch you should use rudder for steering rather than ailerons. In fact, in some situations you may discover that giving ailerons creates the opposite of the desired response because the drag of the down aileron overpowers the lift it creates. This is why I suggest that you learn to use the left thumb for rudder only. You can start out with coupled rudder and gradually reduce the amount of coupling until your left thumb is independent.

Landings are a 'breeze' because now if one wing drops, you will get an immediate response when you give the correcting aileron control. You will find that you don't ground loop or flip over nearly as much.

Multitask Flying

As I mentioned at the beginning of this construction article, the *Hustler* was designed for F3B flying, which these days is also called multitask flying. I believe that you will find the *Hustler* will compete with the best of the multitask planes of its size, and with larger ones as well.

In distance runs, you will want to fly somewhat faster than you fly for thermalling. You can usually anticipate the near-end turn, and the far-end turn should **not** be anticipated because you will have to go back and get it if you're short. The ailerons make pylon turning a snap, because of the instant response. You will find that you can turn in a much shorter distance compared to the poly birds.

For speed, you may want to add ballast. The prototype *Hustlers* were built with 1/2" model rocket cardboard tube ballast carriers. At the '81 World Champs I flew with 24 ounces in the wings and 40 in the fuselage, or a total weight of eight pounds! Needless to say, this takes some getting used to and I would suggest adding small weights, like

four or eight ounces at a time. For turns, you want to anticipate as much as possible, and as soon as the turn signal is received, pull hard on the elevator if you are already banked over. You will have to practice not ballooning upward as you come out of a turn, because this costs both time and energy.

I hope that you enjoy building and flying the *Hustler*. You may find, as I did, that polyhedral wings aren't as much fun any more and that you stick with responsive, high-performance aileron ships!

©2002–present

. All rights reserved.

Resources

- [Hustler Plan PDF \(montaged\)](#) – Included in the key image which appears above the title at the beginning of this article. Note this is the product of a low-precision, cut-n-paste workflow which while suitable for simple review purposes, it should **not** be used where high precision is required.
- [Hustler Plan PDF \(paged\)](#) – The individual PDF pages from which the montage above was cut-n-pasted.
- [Hustler Plan CDD](#) – The original [ConceptDraw](#) source file used to produce the PDFs above.
- [Sagitta 900 Plans](#) by Lee Renaud via Outerzone. – “The *Sagittais* one of the new breed, which has already proven itself a World Class design in both AMA and F3-B competition. First flown on July 20, 1979...”
- [Foam Wings](#) by J. Alexander via RCLibrary in the UK. – “One material that has perhaps done more to revolutionize RC aircraft development and construction in recent years than any other is expanded bead foam...”

Read the [next article](#) in this issue, return to the [previous article](#) in this issue or go to the [table of contents](#). A PDF version of this article, or the entire issue, is available [upon request](#).

- [DraftSight](#) – “The Ultimate Editor for DWG and DXF Files From The Makers of SOLIDWORKS...”
- [Fusion 360](#) – “Unified CAD, CAM, and PCB software...”
- [LibreCAD](#) – “LibreCAD started as a project to build CAM capabilities into the community version of QCad for use with a Mechmate CNC router...”
- [OpenSCAD](#) – “software for creating solid 3D CAD models. It is free software...”
- [QCAD](#) – “a free, open source application for computer aided drafting (CAD) in two dimensions (2D)...”
- [SolidWorks](#) – “SOLIDWORKS® and the 3DEXPERIENCE® Works portfolio unite your entire ecosystem...”
- [XFLR5](#) – “an analysis tool for airfoils, wings and planes operating at low Reynolds Numbers...”
- [XFOIL](#) – “an interactive program for the design and analysis of subsonic isolated airfoils...”
- [Project ALTius](#) on RCGroups. – “altius, citius, fortius – sounds familiar? That’s the Olympic motto where ‘altius’ means ‘higher’. But the spelling (ALTius) is related also to my initials – Atudorei Lucian Tiberiu...”

All images by the author unless otherwise noted. Read the [next article](#) in this issue, return to the [previous article](#) in this issue or go to the [table of contents](#). A PDF version of this article, or the entire issue, is available [upon request](#).

Twist Distributions for Swept Wings



A Penumbra 4 winch launch at 60 Acres Park, at Redmond, Washington.

Part I: Why place proportionally more twist in the outboard portion of the wing?

In addition to the comments provided in this month's In The Air regarding the return of Bill Kuhlman to these pages, I remind the reader that this article originally appeared in the April, 2002 issue of the legacy RC Soaring Digest. See Resources below for link to the original article. — Ed.

Our intense interest in tailless aircraft now spans twenty years. Over those two decades, we have built a number of 'plank' type wings and several swept wings. There are advantages and disadvantages to both of these planforms.

An Introduction to Twist Distributions

The impetus to begin designing our own swept wing tailless aircraft was the presentation given by Dr. Walter Panknin at the MARCS (Madison Area Radio Control Society) Symposium held in 1989. Dr.

Panknin provided a relatively simple method for determining the geometric twist required for a stable planform when given the span, the root and tip chord lengths, the root and tip airfoil zero lift angles and pitching moments, the sweep angle of the quarter chord line, the design coefficient of lift, and the static margin.

Dr. Panknin assumed that the wing twist would be imparted across the semi-span. That is, the root would be held at zero degrees and the tip twisted at some angle of washout, with the wing leading and trailing edges forming straight lines. Dr. Panknin's wing, the *Flying Rainbow*, along with Kurt Weller's *Elfe II*, utilized this type of twist distribution on tapered wings.

In looking at other swept wings of that time period, we were also attracted to Hans-Jurgen Unverferth's *CO2*. The *CO2* was different from the *Flying Rainbow* and the *Elfe II* in that the wing was not tapered but rather of constant chord. Additionally, *CO2* utilizes a twist distribution in which the inner half of the semi-span has no twist at all. All of the geometric twist is in the outer half of the semi-span. While the actual twist angle is identical to that computed for the Panknin twist distribution, pitch stability is not adversely affected and in fact may be slightly better.

More recently, Hans Jurgen and other swept wing designers have taken to imparting wing twist across three segments. From the root to one third of the semi-span there is no twist. About one third of the total twist is then put into the second third of the semi-span, and the remaining two thirds of the total twist is put into the wing between two thirds semi-span and the wing tip.

Our curiosity got the better of us and we asked, "Why are designers of swept wing tailless models placing proportionally more twist in the outboard portion of the wing?" This series of articles will provide a comprehensive answer to that question.

Lift Distributions

Nearly all aerodynamics text books devote pages to what is called the 'lift distribution'. The lift distribution for any straight (quarter chord line at 90 degrees to the centerline) wing can be graphically represented by a curved line superimposed over a standard X-Y coordinate system. The lift distribution curve traces the local circulation – the local coefficient of lift times the local geometric chord.

How is the lift distribution determined? Let's start by taking a look at the construction of the elliptical lift distribution. Assign the aircraft wing tips to the points 1.0 and -1.0 on the Y-axis of the coordinate system. Draw a circular arc above the Y-axis using the aircraft wing tips to define the diameter. A semicircle is formed which has the radius $b/2$ (the semi-span) and the area $\pi/2 (b/2)^2$ which in this specific case is simply $\pi/2 = 1.57$.

Now drop vertical lines from the semicircle circumference to the Y-axis. Mark the mean (halfway) point on each vertical. Connecting these identified points creates an ellipse. (See Figure 1).

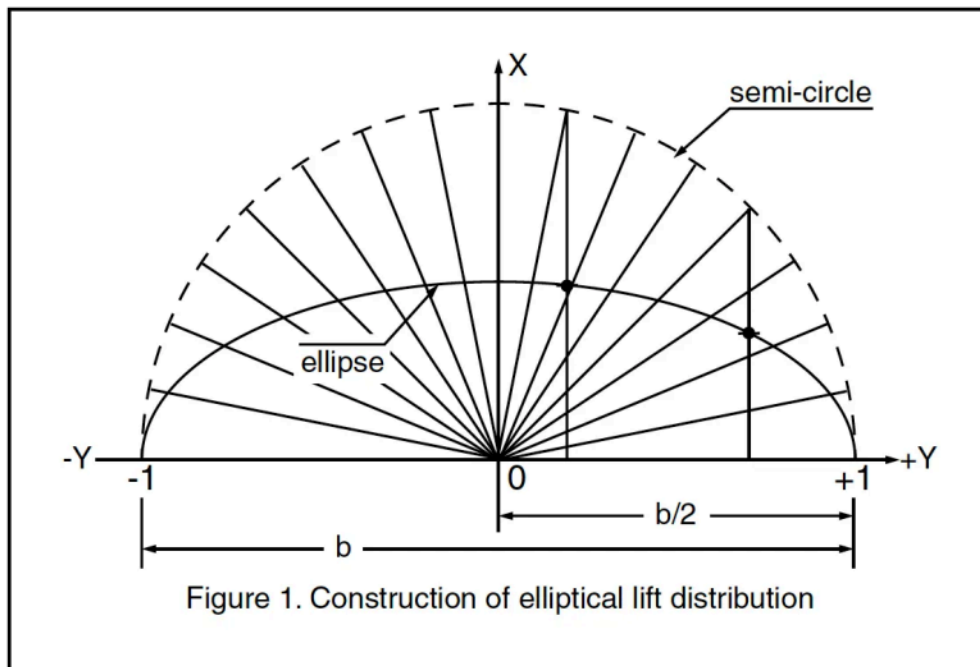

This elliptical lift distribution is predominantly promoted as being the ideal, as represented in the planform of the British Supermarine Spitfire fighter of the World War II era.

Why would the designer want the lift distribution of his arbitrary wing to closely match that of the elliptical lift distribution? Because with the elliptical lift distribution, a discovery of Ludwig Prandtl in 1908 which he published in 1920, each small area of the wing is carrying an identical load and so is operating at the same local coefficient of lift, the downwash off the trailing edge of the wing is constant across the span, and the coefficient of induced drag (drag due to lift) is at its minimum point.

To construct the lift distribution for an arbitrary wing without twist or sweep, lay out the wing outline over the elliptical lift distribution with chord lengths proportioned such that the area of the wing is equal to that of the ellipse (one half that of the semicircle, in this case $\frac{\pi}{4} = 0.785$). Draw a curve along the mean of the ellipse and the wing planform outline. (See Figure 2.)

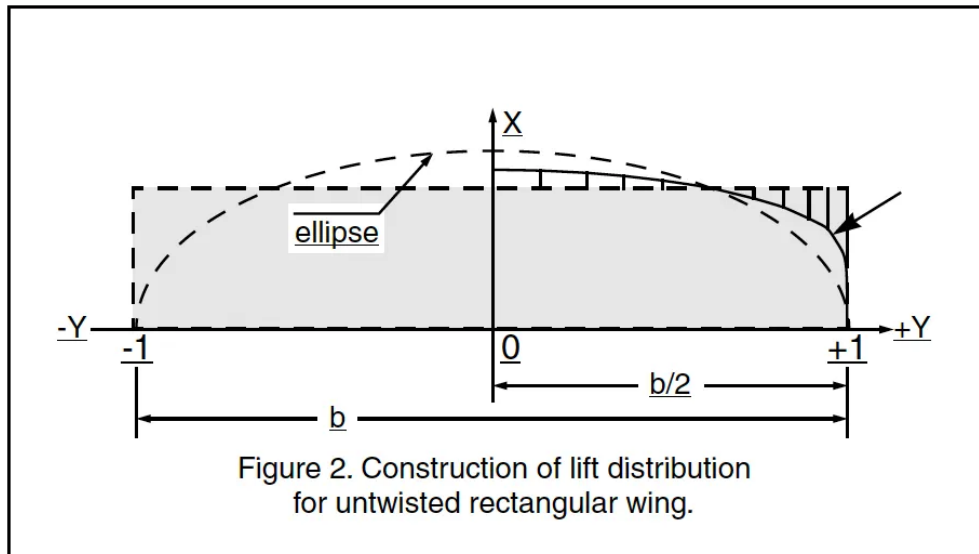

With some graphical experimentation, we find that the lift distribution for a wing with a taper ratio of 0.45 almost exactly matches that of the elliptical lift distribution described by Prandtl. (See Figure 3.)

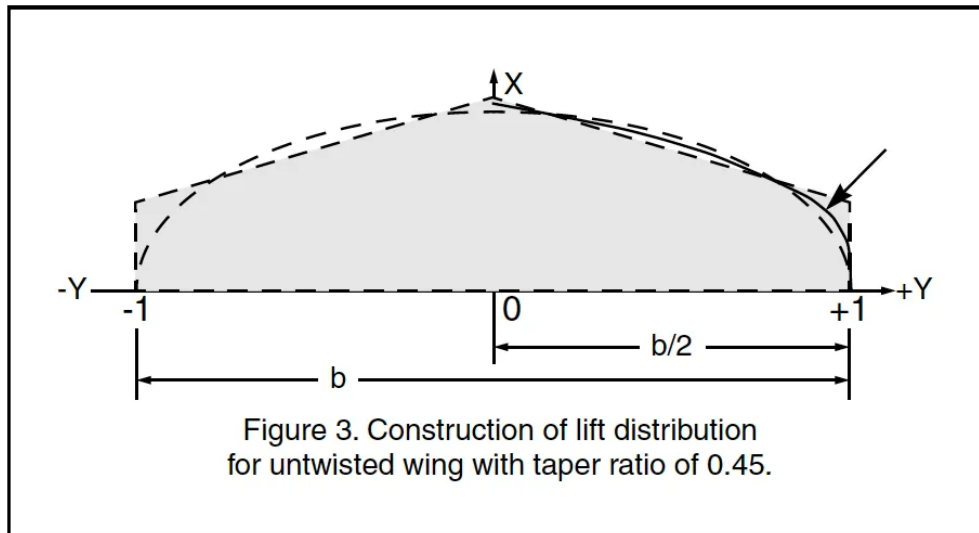

The tapered planform has at least one advantage over the elliptical planform – it's far easier to build. But the elliptical planform has a stall pattern in which the entire wing is subject to stalling at the same time. At high angles of attack, small gusts can serve to trigger a stall on any portion of the wing span. A tapered wing with a nearly identical lift distribution will tend to behave in the same way.

Lift Coefficient Distributions

As stated previously, the lift generated by any wing segment is directly proportional to the coefficient of lift and the local geometric chord. This means that there is also a coefficient of lift distribution. For Prandtl's elliptical wing lift distribution, as has been described here, the local coefficient of lift is identical across the span. On the other hand, if the taper ratio is zero (the wing comes to a point), the coefficient of lift at the wing tip will be zero only in a truly vertical dive, otherwise it will be infinite because the wing tip chord is nil. Any time this wing is called upon to produce lift, the wing tip will be stalled. From this extreme example, we realize the tip chord cannot be too small, as it will then be forced to operate at a higher coefficient of lift, leading to a local stalling of the wing. (See Figure 4.)

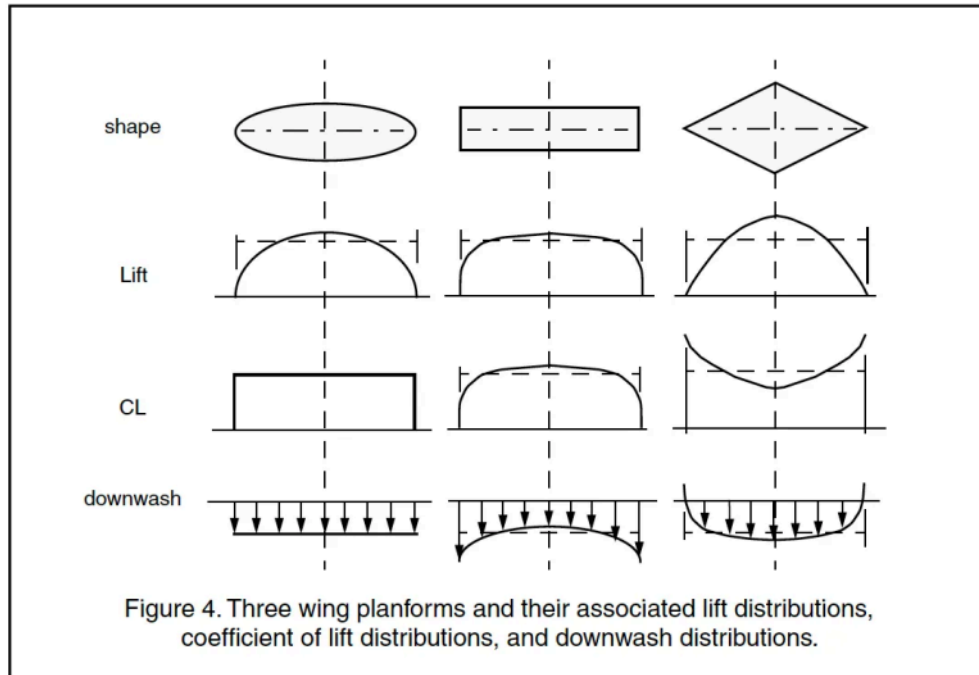

So called 'tip stalling' can be inhibited by one or both of two methods. The first involves increasing the local chord near the wing tip, the second consists of imparting washout.

As we intuitively know, enlarging the wing tip chord reduces the local coefficient of lift. An enlarged wing tip chord is not so efficient as the true elliptical planform, but the penalty for using a perfectly rectangular wing is just 7% and so it may be an acceptable trade-off for a machine designed for sport flying.

Washout, on the other hand, while also reducing the coefficient of lift in the area of the wing tip, is good for only one speed. As the twist angle increases, the deleterious effects become stronger much more quickly as the coefficient of lift for the entire wing, C_l , moves away from the design point. If washout is too great, the wing tips can actually be lifting downward at high speeds. This puts tremendous loads on the wing structure.

Adverse Yaw

One other effect of utilizing the elliptical lift distribution comes about as we add control surfaces to the wing. Outboard ailerons, for

example, create different coefficients of induced drag depending on whether the surface is moved up or down. The control surface moving downward creates more lift and hence more drag than the surface moving upward. When rolling into a turn, therefore, the aircraft is forced into a yaw away from the direction of the turn. (See Figure 5.)

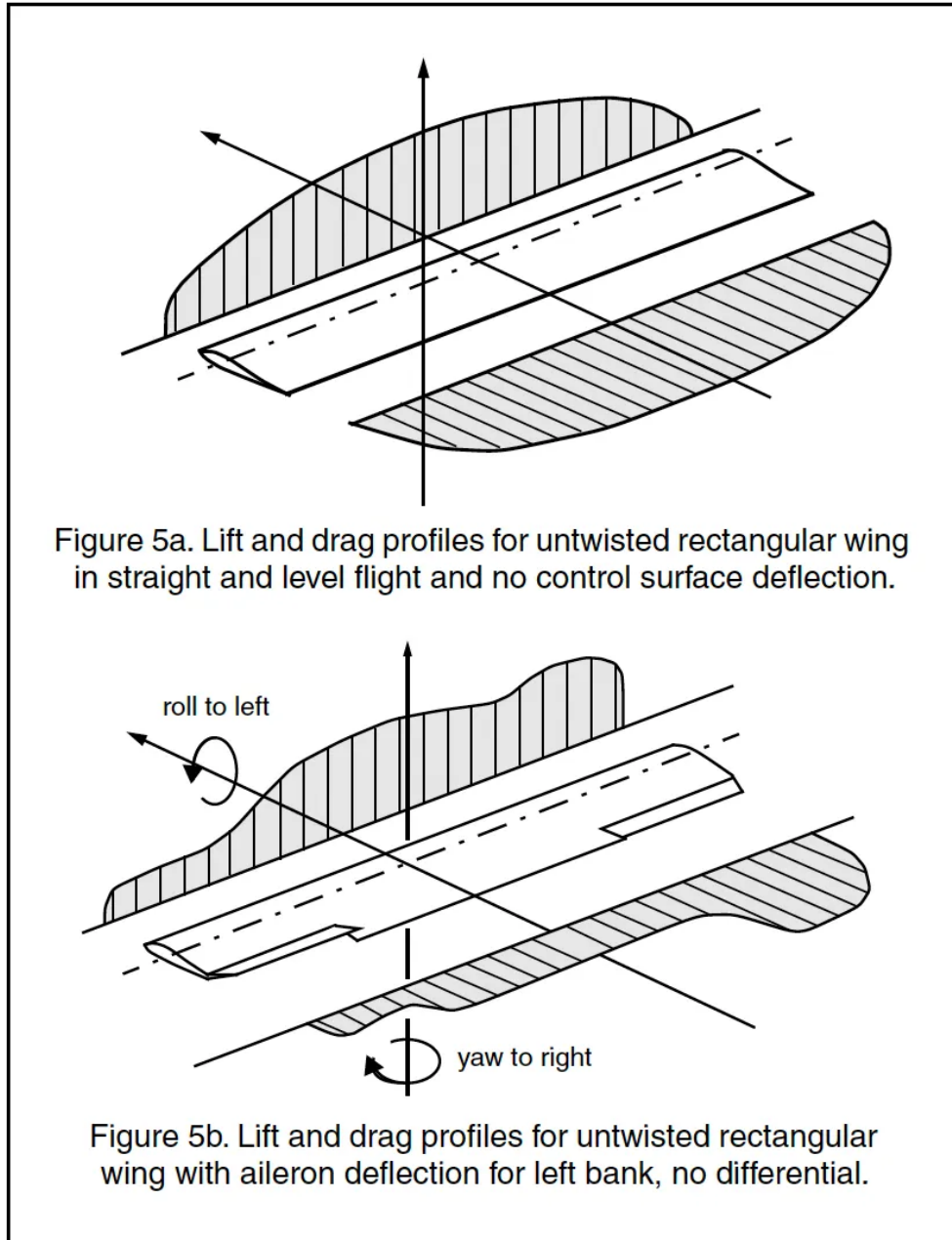

In conventional aircraft, this tendency can be reduced to some extent by what is called aileron differential. The upgoing control surface travels through a larger arc than the downgoing surface. While this tends to increase the drag on the downgoing wing, reducing adverse yaw to a great extent, many pilots find that some amount of rudder input is necessary to obtain a coordinated turn.

Reduction of rudder input is an important consideration in the quest to reduce overall drag while maneuvering, but the associated induced drag from the fin and rudder, a low aspect ratio flying surface, cannot be entirely avoided. For a swept flying wing without vertical surface, elimination of adverse yaw is obviously imperative, but aileron differential cannot be used in this case because of its effect on pitch trim. Some other means of eliminating adverse yaw must be devised.

Three Major Problems

And so we are forced to solve three problems when designing a tailless aircraft:

1. achieve and hopefully surpass the low induced drag as exemplified by the elliptical lift distribution without creating untoward stall characteristics,
2. reduce the adverse yaw created by aileron deflection without adversely affecting the aircraft in pitch, and
3. maintain an acceptable weight to strength ratio.

A Relevant Historical Tidbit

The Wright brothers, along with their other accomplishments, were the first aircraft designers to determine that banking was necessary to turn, an idea which no doubt came from their experience with bicycles. While other early aviation pioneers had studied bird flight, the perspective of the Wrights while watching birds was very much different because of their cycling experiences. (Interestingly, their direct competitor, Glenn Curtiss, built and raced motorcycles.)

The Wrights also had the ability to separate the major problem of controlled powered flight into manageable components. Propulsion was separated from the production of lift, and stability was separated from control, for example. In fact, their solution to the problem of flight incorporated only one integrated system, the wing, which provided lateral control, structure, and lift. It was Wilbur's twisting of

the inner-tube box, through which the idea of wing warping was derived and the internal bracing of their wing structure was devised, which provided the insight needed to create a controllable flying machine capable of carrying a human pilot/passenger.

But the flying machine they created, while tremendously successful, for all practical purposes ended the use of birds as models for aircraft design. As an indicator of this, the Wrights saw their early successes and records in powered flight quickly surpassed by the inventions of others. Curtiss, for example, solved the problem of banking turns with separate control surfaces rather than wing warping. His aileron system is still in use today.

The Wright's separation of a huge problem into smaller more easily solved problems has continued to be the hallmark of aircraft design for 100 years, and aviation has made nearly unbelievable strides during that century. But there are a growing number of aircraft designers who wish to go back to the bird model. They wish to design an aircraft which is the minimum required for efficient controlled flight by integrating lift, stability and control into a single structural component.

A bird is a biological system which has been very successful for a very long time. To be successful in the competitive environment of nature, a flying bird needs more than just lift, stability, and control. A bird must also be efficient at flying. That is, it must have a very low energy expenditure. Minimum drag while moving through the air is of course of major importance in this regard, as is a very light airframe because extra weight increases the energy drain on the system.

We can see through direct observation that birds have no vertical surfaces, yet birds are able to make beautiful coordinated banked turns without any evidence of adverse yaw. Perhaps birds do not make use of Prandtl's elliptical lift distribution.

What's Next?

As a prelude to future installments, let us ask a series of provocative questions:

- What if we found that the elliptical lift distribution does not lead to the minimum induced drag, as has been dogma in most aerodynamics texts since Prandtl introduced the concept in 1920?
- What if we found a way to produce 'induced thrust' in addition to, and without increasing, the 'induced drag' produced by the creation of lift
- What if we could increase the wing span and aspect ratio without increasing the required strength of the spar at the wing root?
- What if the answers to all of the above questions are related?

We'll cover all of this and more in future installments!

©2002, 2023

References

1. Anderson, John D. Jr. Introduction to flight. McGraw-Hill, New York, 1985.
2. Anderson, John D. Jr. Fundamentals of aerodynamics. McGraw-Hill, New York, 1984.
3. Bowers, Al. Correspondence within <www.nurflugel.com> e-mail list.
4. Hoerner, Dr.-Ing. S.F. and H.V. Borst. Fluid-dynamic lift. Hoerner fluid dynamics, Vancouver WA USA, 1985.
5. Horten, Dr. Reimar. Lift distribution on flying wing aircraft. Soaring June 1981, pp. 40-42.
6. Hurt, H.H. Jr. Aerodynamics for naval aviators. Published as NAVWEPS 00-80T-80 by the U.S. Navy, 1965.
7. Kermode, A.C. Mechanics of flight. Pitman, London, 1980.
8. McCormick, Barnes W. Aerodynamics, aeronautics, and flight mechanics. John Wiley and Sons, New York, 1979.
9. Raymer, Daniel P. Aircraft design: a conceptual approach. AIAA Education Series, Washington, DC, 1992.
10. Shevell, Richard S. Fundamentals of flight. Prentice-Hall, Englewood Cliffs NJ USA, 1983.
11. Simons, Martin. Model aircraft aerodynamics. Argus Books, Hemel Hempstead Great Britain, 1994.
12. The White Sheet, Spring 1986, No. 36. Sean Walbank editor. White Sheet Radio Flying Club, Dorset/Somerset Great Britain.

Resources

- [Twist Distributions for Swept Wings, Part 1](#) by Bill Kuhlman. — The original version of this article, exactly as it appeared in the April, 2002 issue of the legacy *RC Soaring Digest*.

All images by the author. Read the [next article](#) in this issue, return to the [previous article](#) in this issue or go to the [table of contents](#). A PDF version of this article, or the entire issue, is available [upon request](#).

Replacing a Wing Servo in a Glass Slipper Wing



Tired of hassling with servo frames in ridiculously tight spaces?

I have an old, beaten up RCRCM *E-Typhoon*, now in its ninth year of use and abuse. She's been repaired several times, the wings are not as stiff as they used to be, and she looks like she's been through several battles: some won, some lost. But she still flies great; it's like putting on your favourite running shoes to go for a run. Comfortable, familiar, fun.

Last flying session I had a bit of a hard arrival. Couldn't call it a landing really. At best a one-pointer: right on the nose. I had to replace the spinner and prop, no further damage. While at it, I also replaced the receiver (Rx), as I am refitting my fleet to Futaba. So when all was connected, I did some table flying – without the prop – to program my transmitter (Tx). One flap servo heated up and stopped working. I've had similar problems with this brand and type, so I yanked it out and looked in my spares drawer for a replacement.

Here's how I, and most members of my club, do it. I'm not reinventing the wheel here. It works for us, as long as you have a regular pushrod setup – not a linear drive system or other fancy stuff – and don't do DS (dynamic soaring). We use it for all our F5J and F3F gliders.

To start, first prepare the servo. Trial fit, and remove any or all of the lugs to make it fit in the servo well. Center the servo arm by either connecting the servo to your Rx/Tx, or a servo tester. If it is a flap servo, centre, and then position the servo arm 15 to 20° off centre to get maximum flap throw.

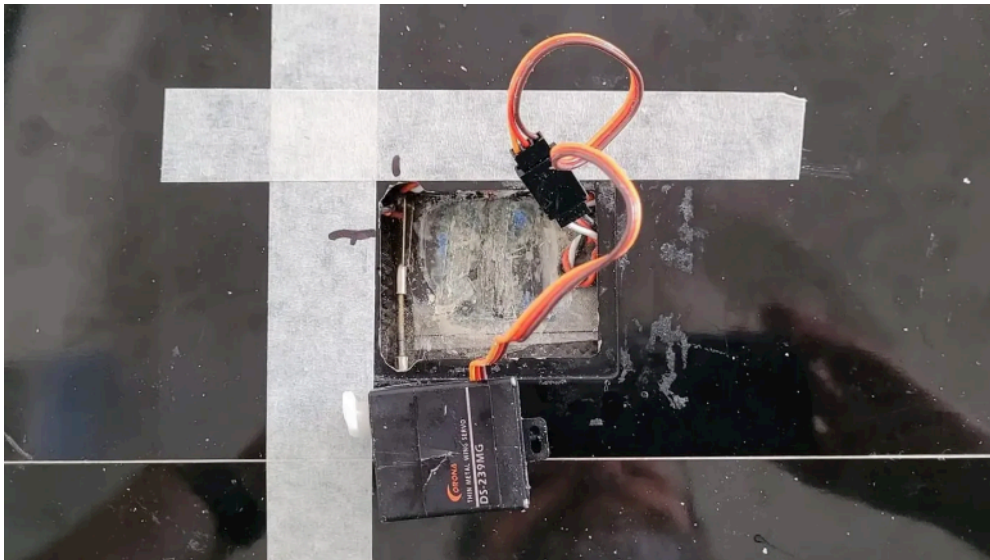

Get some heat shrink tubing that fits the servo. You can get all kinds on the internet, just make sure it is not the rubbery one. Glue doesn't adhere to it so well – I can write you another article on how I found out!

As noted above, remove any or all tabs from the servo, so it fits easy in the servo well, screw in the servo arm set screw, and tape the servo wire to the servo housing, so it'll come out of the heat shrink tubing where you want it.

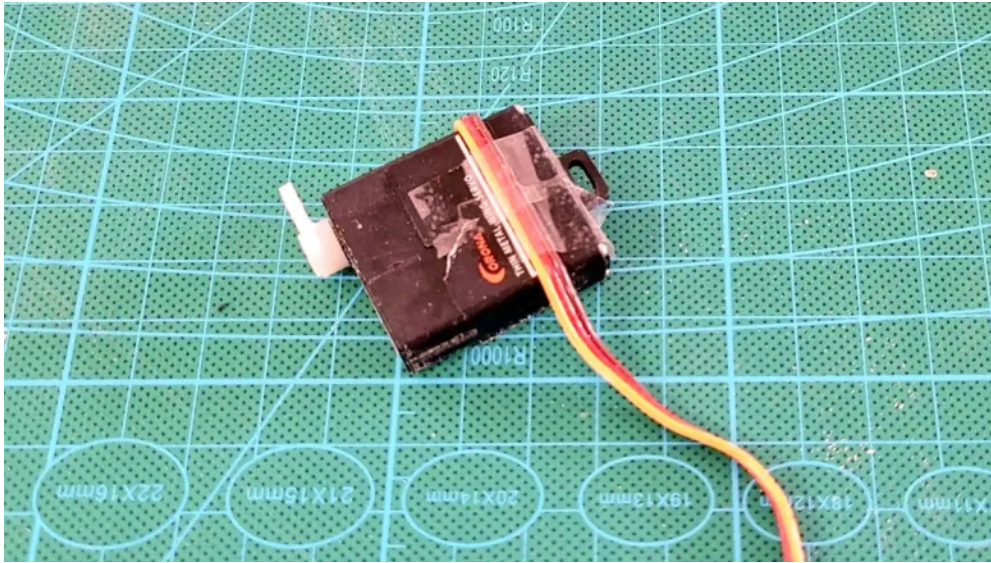

Fit the heat shrink on the servo keeping in mind where you want the servo wiring to exit, and zap it with a heat gun. Hold the servo with a pair of long needle nose pliers while you do that. Or burn your fingers, whatever you prefer.



When shrunk, let it cool for a bit, and then cut off any excess heat shrink and making sure **not** to slice through the servo wire! (Yeah, I got the t-shirt for that one as well).

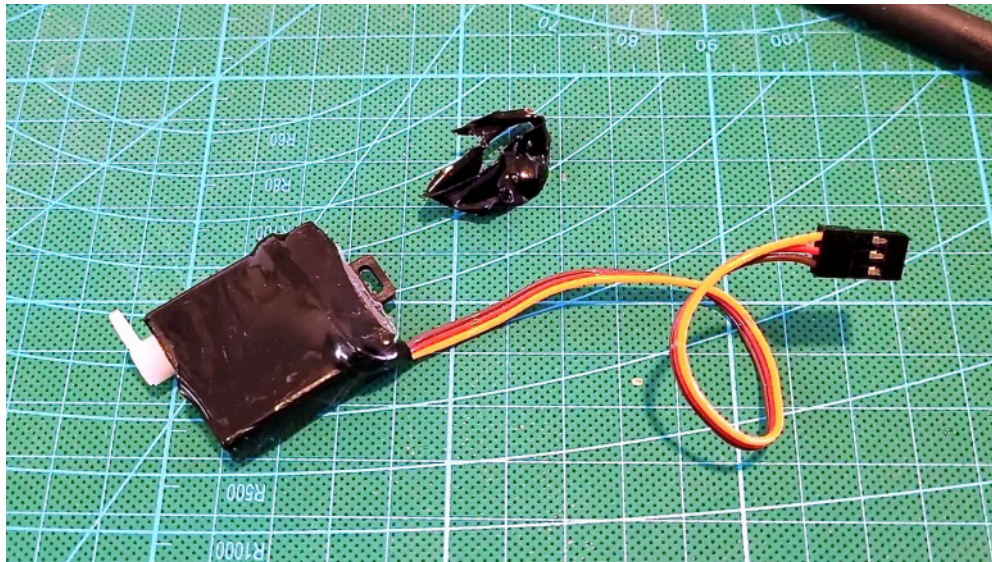

Now to prepare the servo well in the wing. The previous servo was glued in as well, so I needed to clear any glue remnants. I do that with a flat grinding stone attachment to my Dremel. This must be done very slowly and carefully – you don't want to Dremel a hole in the wing! Make sure all wiring and the pushrod are well out of the way, and keep them there with masking tape. To keep the pushrod out of harm's way I put a screwdriver through the clevis. You can use any stick of wood, toothpick or similar and tape it in place as well.



Use a well lit, well ventilated area and wear a face mask. If you can, do it outside. Now grind away all glue residue, until you have a more or less clear, flat area. I find it best to put the wing on a table, weigh it down with some magazines so it won't wander while I'm working on it, and hold the Dremel with two hands. The name of the game is *go*

ssssssllllllloooow and steady. I use only the flat bottom of the grinding stone. Don't get tempted to use the sharp edge. You'll be through the wing skin in a matter of milliseconds – and yes, I got the t-shirt to prove it.

Once done, trial fit the servo, and make sure it doesn't wobble due to an uneven servo well. Measure where the servo should be, and mark it on the masking tape you have put around the servo well. Give both the servo and the servo well a rough sanding, so the glue has something to hold on to, and clean all areas with some alcohol. I use the stuff my wife and daughters use for their nails.



Move all wiring and the pushrod out of the way. Use masking tape if needed. Have some handy weights ready to put on the servo, to have some pressure while the glue cures. If the servo is below the wing surface, you will need something to put on the servo – like another servo or a piece of balsa – and put the weight on that. You don't need a ton of bricks. I use some fishing weights, totalling just under 100g.

So all is sanded, cleaned, and taped out of the way. I use thick CA for the next step. I've tried different brands and types of epoxy, I've tried UHU, I've tried Gorilla Contact Glue. They all failed after a very short while. Either on the servo side or the wing side. Only thick CA has lasted years with me.

So, a splodge of thick CA on the servo – not too much as you don't want it to ooze out on all sides – press it into place, making sure the servo arm is in the right place *and* make sure there is no glue anywhere near the servo arm. Yes, I have glued in a servo – and after curing found out the servo arm couldn't move because I had glued it in place *with* the servo.

Once you're sure it is all where it should be, put some weights on the servo. Do this **carefully** without moving the servo. Thick CA does not cure as quick as thin or medium CA. Just leave it alone for an hour or so. There's really no need to heap on huge weights. All you want is to put some pressure on the servo so it settles nicely on top of the CA. In the picture below you can see I placed a box of X-acto knife replacements and some fishing weights, totalling just over 100g on top. Personally, I like to leave it overnight this way. You could use a kicker, but as the glue is under the servo, not all CA may be affected by the kicker, and then you'll get uneven curing which may – or may not – affect the long term use.



After curing, make sure the servo will not budge if you try to move it. Now re-attach the pushrod. Because I use a different brand/type servo, I needed to adjust the pushrod length by turning the clevis. After a bit of trial-and-error I got it right. If you ground a bit of the clevis down, so it won't bind with the servo arm's root, make sure the clevis is the right way up.

Before going any further, plug in a servo tester or your Rx/Tx, and make sure it all works. You might want to remove any masking tape you put over the flap or aileron first.

If all's well, the servo works, you get the throws you need, and the servo doesn't show any flex or binding, we can do the last bit. To make sure the servo has some help to stay seated, I like to add some fillets on at least two sides of the servo. Here I like to use medium CA mixed with micro balloons. The medium CA thickens nicely with the balloons, and is relatively easy to push in place with a lollipop stick or even a toothpick. I did one side at the time, and you'll see why. I made the CA/balloons mixture about 50/50, and with a lollipop stick pushed it right next to the servo. Then I tilted the wing about 45° to keep the CA mixture from lying flat, and make a nice fillet between the servo well floor and the servo. I held it like that for a few minutes, keeping an eye on it, to make sure it didn't leak where it shouldn't go. Then I hit it with some kicker. Before doing the second side, I gave it 20 minutes or so for the kicker to evaporate. Then I repeated the process on the other side.



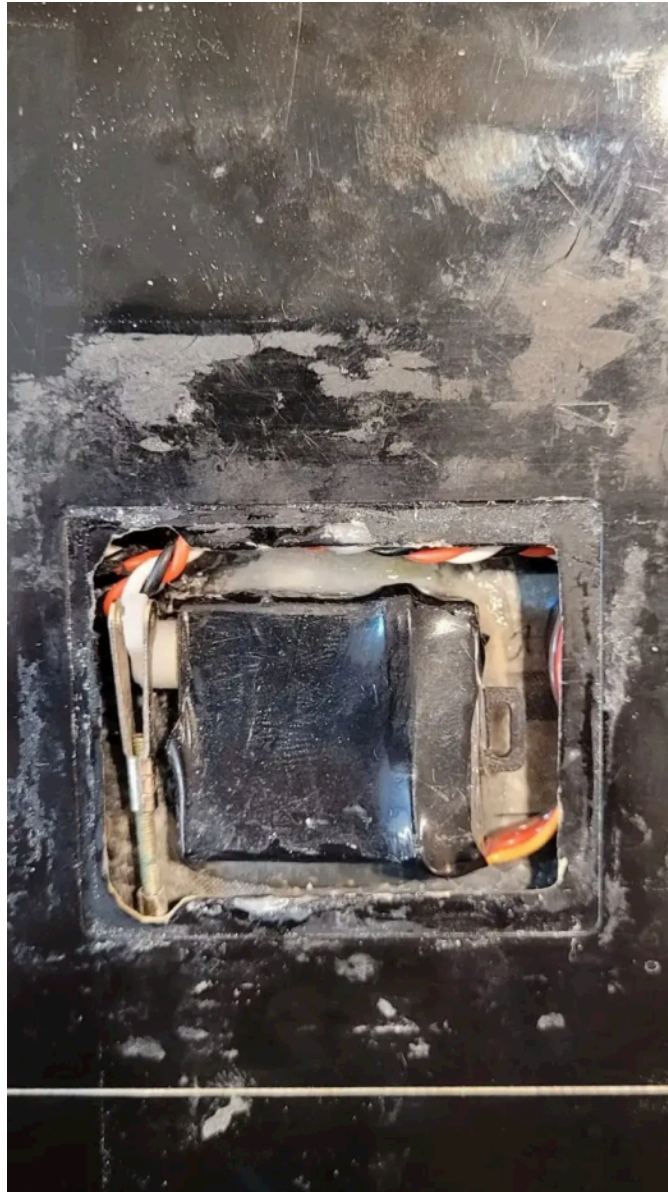

All that is left now, is to plug the servo into the wing wiring – don't forget to tape up the connectors! – make sure all wiring is in place and can't run foul with the servo arm and pushrod, and then tape the servo cover in place **DONE!**

Why Do It This Way?

There are lots of different ways to mount servos, so what's to recommend *this* way of doing it?

- No hassle with servo frames
- No problem inserting a differently shaped servo from the original one

- Large glue area will keep the servo in place better
- To remove, simply cut the heat shrink and pop out the servo
- KISS (that is, “keep it simple...silly”)

Thanks for reading, good luck with your own re-servoing project and see you on the flight line or slope!



Flying on the east shore of the Lake of Tiberias. (credit: Eyal Radomsky)

©2023

Resources

- [*E-Typhoon*](#) – “ outstanding performance and excellent thermal flight qualities. The flight of the Typhoon is highly agile and maneuverable, it will go where you like in a dream. It is able to fly in virtually all conditions...”

All images provided by the author unless otherwise noted. Read the [next article](#) in this issue, return to the [previous article](#) in this issue or go to the [table of contents](#). A PDF version of this article, or the entire issue, is available [upon request](#).

Science for Model Flyers



A wide variety of aerial setups on the flight line at the GPS Sport Class World Championship held at Sportfliegerclub in Ulm, Germany in 2022. (credit: Iain Medley-Rose)

Part IV: Aerials

Although by no means is it a prerequisite, you may want to read the [preceding parts of this series](#) before reading this next instalment. — Ed.

When we switch on our transmitters we unleash energy that was identified and studied by some of the cleverest people ever. I will tell you about the most remarkable, but the list could be very much longer. Very. My choices are Isaac Newton, Thomas Young, Michael Faraday, Charles-Augustin de Coulomb, Johann Gauss, Chandra Bose, James Clerk Maxwell, André-Marie Ampère and Heinrich Hertz (see *On the Shoulders of Giants* in *Resources*, below). In our field I would vote for Maxwell or Bose as the most important from that list. What is remarkable is how long ago the foundations were laid and how young many of the workers were when they died. As usual I have included

brief word sketches of the scientists. Puzzle corner: whose mother was called Peppercorn?

We fill the space around us with waves that travel away at great speed and are absorbed by the people nearby, the ground, trees and plants, buildings, the air and hopefully one or more aerial wires in our models. This article will try to explain the science behind it and the people involved. So it is about waves and why they are important to aeromodellers. I make no apology for using the English name for aerials. Aerial has the sense of an aetherial something going somewhere or 'girdling the earth' to quote *The Tempest*. Elsewhere they are called antennae, which conjures up insects for me.

At its simplest an aerial is a piece of wire. It might be a hundred metres long or shorter than a centimetre. It is connected at one end to an electrical device – a transmitter – that sends energy up it by applying alternating voltages. The voltages and the resulting currents, produce electric and magnetic field waves that spread out from the aerial at the speed of light. Some reach an aerial in our receiver and allow us to control our models. The waves carry the information about what we want our servos and motors to do, called modulation.

Of course it isn't that simple. Using a feedwire, the aerial has to be connected to the transmitter circuit that creates the voltages. How we connect the feedwire has a big effect on the power the aerial can send out.

Thought Experiment

Imagine a river. The water flows steadily pulled by gravity. If the width of the river is constant the water will flow smoothly. Suppose the river suddenly narrows perhaps due to a bridge arch. The water that cannot flow directly through the arch will be pushed back upstream and some energy will be lost. A turbine well upstream of the arch will generate maximum power. Below the arch the power will be less

depending on how narrow the arch is. How rough the water is where it has been reversed is a guide to how much of it is reflected.

At one time I taught Physics in secondary (high) schools. I was a member of the UK Association For Science Education. I remember many articles and letters from teachers in Africa explaining how they did 'bucket science' with little or no money. Their ideas were excellent and I made use of them. You can do a lot of science with everyday objects or even none. I have included seven bucket experiments here for you to try.

From 1928 to 2001 Scientific American magazine included articles called *The Amateur Scientist* telling you how to carry out home experiments. I particularly remember one describing how to build an ultra-violet laser that carried a hazard warning. In these absurdly litigious days I suppose such things can no longer be published. The articles are still available on compact disk and are well worth a look for children of all ages. I used some of them as holiday projects for my advanced Physics students. The experiments in this article are safe of course (apart from retribution).

What Are Waves?

Waves are moving energy. They carry the energy from a source to something that absorbs it. For example a moving boat will produce waves in the water that will make a duck bounce up and down or might erode the river bank. Water waves move up and down at right angles to the direction of travel. They are called transverse waves. Most waves are like this. What they travel through is called the medium. Usually this is a solid, liquid or gas. How can a solid carry a wave? Remember earthquakes. There is another kind of wave where the medium moves backwards and forwards in the direction of travel. These are called longitudinal waves, the most common example being sound waves. After all these are pushed and pulled by a loudspeaker cone.

Light, and other waves like it, travels invisibly through the medium of space. Light – invisible? It's only when it hits something and makes it glow that we are aware of light. In this article it is these light-type waves, called electromagnetic waves, that we are studying. However I will use other more tangible waves as analogies. We must not forget that an analogy is not the real thing. It is there to help us to visualise something but will have limits to its accuracy.

In Picture 1 are the wave shape, dimensions and some words that we will be using. This type of wave is called a sine wave. In Picture 1 there are two complete waves. The symbol for wavelength is the Greek letter lambda λ . Another word we must understand is frequency f . This is how many times the wave vibrates each second. It is measured in hertz (Hz), where one hertz is one vibration per second. Waves travel at a certain speed given the symbol v , or c in the case of light.

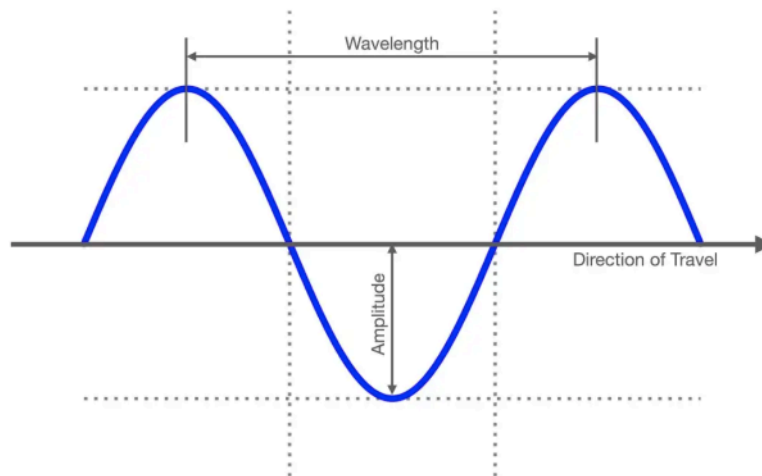

Picture 1 (credit: Peter Scott)

The quantities are related in the formula:

$$v = f \lambda$$

So, for a given speed, as frequency goes up wavelength goes down. Waves travel at different speeds in different media, or in the case of water at different depths. That is one reason why waves break on the seashore.

Experiment Nº1

Find a piece of rope. Tie each end to a strong, fixed object. You could use an empty washing line but take care not to break it or revenge will be swift. Waggle one end up and down gradually getting faster. At certain speeds you will see one, two or more loops appear with places where there is no movement. These places are called nodes and the waves are called standing waves. The places of maximum amplitude are called antinodes. The frequencies at which standing waves appear are called resonant frequencies.

Standing waves are the result of the 'reflected' waves bouncing back from the far end. They mix with the outgoing 'forward' waves. In some places they add together (antinodes), called reinforcement and in other places they subtract, called cancellation (nodes). As you will learn later this is important in setting up aerials.

Something to note. Once the rope is vibrating it takes little energy to keep it moving. Similarly when pushing someone on a swing only small pushes are needed to keep the amplitude of the swing constant. The message is that something absorbs energy very efficiently if we give it at one of its resonant frequencies.

The rope can resonate at several frequencies. The lowest, called the fundamental frequency, is where there is a single loop, which is half the wavelength. In a string instrument the string will also vibrate at two, three, four and higher times the frequencies at the same time. These are called overtones or harmonics. You can see this in Picture 2. Wind instruments also have harmonics but strings are simpler to visualise.

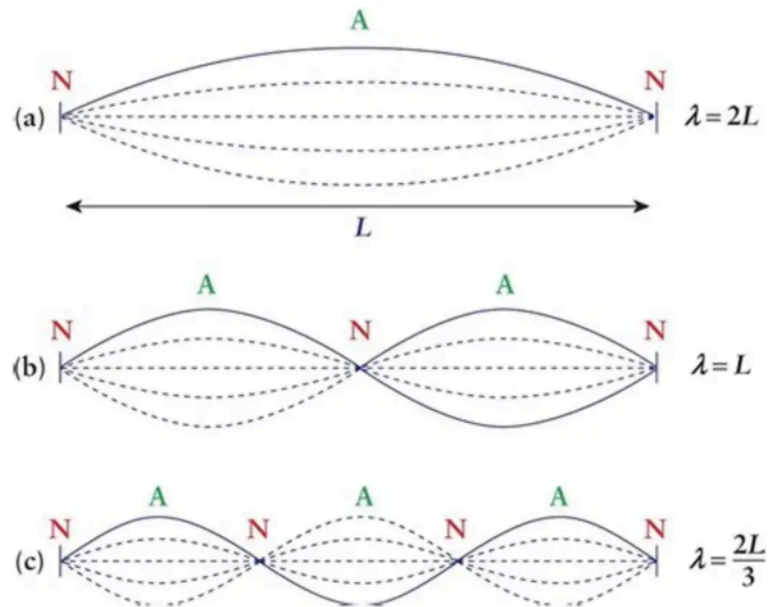

Picture 2 (credit: schoolbag.info)

A violin has up to twelve overtones. It is the mix of these overtones that gives violins, and other musical instruments, their characteristic sound or 'timbre'. It's also the reason a skilled player can make an instrument sound sweeter. In the case of the violin it is by the way he or she bows the strings to give a pleasing mix of overtones, and why hearing someone learning the violin is such a painful experience. If a skilled guitar player touches the centre of a string as he or she twangs it, it vibrates at double the frequency with a strange, ethereal sound of double the frequency, which is an octave higher.

▶ Experiment N°2

You can also make the water in a bath or tank resonate. Put about 15cm of water in a bath. At the curved end move your hand backward and forward to push waves down the bath. They bounce back from the square end. Adjust the frequency of the pushes until you start to get standing waves. Take care. They will build up and you could find yourself with wet feet and an angry partner. Perhaps I shouldn't have said these experiments were safe!

▶ Experiment N°3

This illustrates how something that resonates at a particular frequency will pick up and appear to amplify a vibration (signal) at that frequency. The kit is shown in Picture 3. How you do it depends on what you have to hand. You need a string stretched fairly tightly between two firm objects and a set of pendulums (A to F) of differing lengths. You don't have to have six. The weights can be almost anything not too heavy but must all be about the same weight so removing that as a variable. You need another pendulum (X) with a slightly heavier weight on it. Vary the length of that and make it swing. Any other pendulum close in length will start to swing too. The others won't or not much. If the lengths are exactly the same the transfer of energy will be striking. Vary the length of the input pendulum (transmitter) and see which other pendulum (receiver) moves most. What will happen if a receiver is half or double the length? Try it.

Our radio control receiver is tuned to the frequency of our transmitter. It picks up the signal vibrations extremely well and rejects the rest and the circuit is much better at rejecting other frequencies than our pendulums. This rejection quality is called Q, chosen by its inventor K. S. Johnson of Western Electric not because it is the first letter of quality but because all other letters were already used for something.

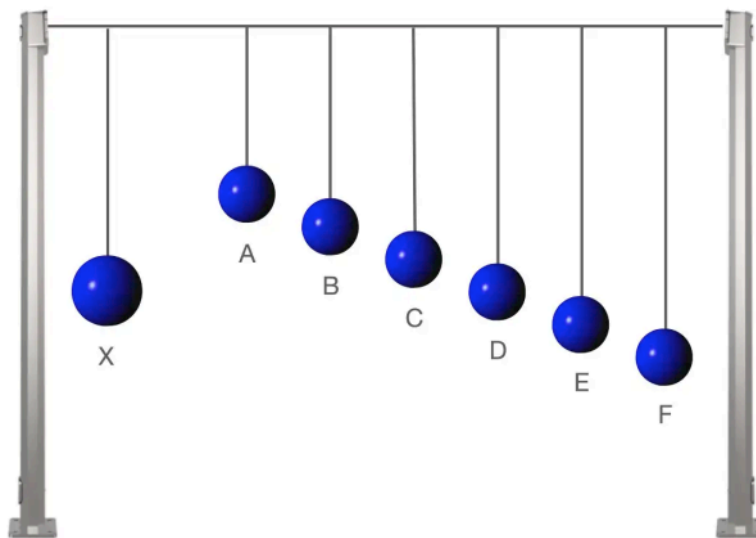

Picture 3 (credit: physicsonlinetuition.com.my)

Impedance and Standing Wave Ratio SWR

When a steady voltage is applied to a conductor the current depends on the resistance in the wire. When you put a varying voltage on the wire it is more complicated. The varying current creates a varying magnetic field. Weirdly the field induces a voltage in the wire that opposes the original voltage. This 'back EMF' reduces the current, so is in effect additional resistance. We call it reactance, but it is still measured in ohms. The more rapidly the current goes up and down the bigger the induced voltage and the higher the reactance. The resistance and reactance added together are called impedance. So impedance in a wire goes up as the frequency of the signal current increases. In some older high quality loudspeakers there is a 'cross-over' device that cuts off the higher frequencies from the bass woofer using the reactance of a wire coil. Now it is more often done with circuitry. An item of clothing on the washing line in experiment one is analogous to reactance. Here it is the inertia of the mass – a sort of back force – that reduces the amplitude. Look at overhead power lines. Some have small T-shaped objects hanging from them usually near a tower. These are made of rubber sheets and absorb the vibrations in the wires caused by the wind. These could build up and make the wire oscillate and possibly touch other wires. Near me I have watched a pheasant being fried when standing on one phase wire and being touched by another one waving about wildly in a high wind. Even the phase to phase 440 V is bad news for a bird.

Imagine a wire, called a feedwire, going from the transmitter circuit board to an aerial. The impedance of the co-axial cable used for feedwires is usually 50 or 75 Ω . In our transmitters it is 50. If the impedance of the aerial is the same as that in the feed wire the signal currents will flow with little loss. However if, for example, the impedance of the feedwire is 50 Ω and the aerial is 100 Ω some of the power will be reflected back from where they join, similar to the water hitting the arch. As you saw earlier, when there are two waves travelling in opposite directions, in some places they add and in some they subtract, which as you know is called reinforcement or cancellation. The greater the reflected energy the less energy will go into the aerial. This is called an impedance mismatch.

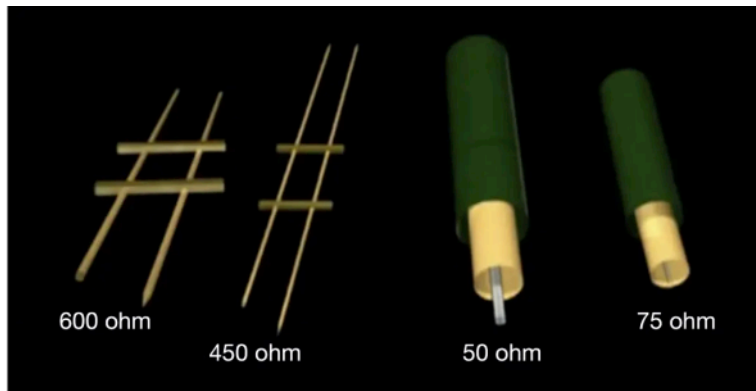

Picture 4 (credit: Pulsecommunications)

Picture 4 shows old-style open wires used for aerial feeds and the coaxial ones mostly used now, along with typical impedances. Coax varies in quality, particularly the screening around it shown in yellow. It is possible to correct for mismatched connections. You use a transformer device called a balun (**balanced to unbalanced**) and normally pronounced bay-lun.

Picture 5 is what a screened television co-axial wire looks like. The outer screen in the best quality wires have a thin sheet of copper rather than braid, but they are more likely to be damaged if bent sharply.



Picture 5 (credit: Pacer Group)

The usual test of how well feedwire and aerial are matched is standing wave ratio (SWR). You measure the maximum and minimum standing wave amplitudes and divide the first by the second. The best case is that the SWR is 1 where the impedances match. 50Ω feeding 100Ω will give a SWR of 2.

In his excellent article titled *Understanding SWR by Example* (see *Resources*, below) Darrin Walraven says this: “*The 33 percent reflection from the antenna [where it joins the feed wire] alternately*

adds to and subtracts from the forward voltage wave. At some places on the cable the reflected voltage adds to 133 percent, and others it subtracts to 66 percent of the matched transmitter output. The voltage ratio is 133/66 or 2.0. That voltage ratio defines the SWR."

For us the message is regularly to check the SWR of our transmitter aerial if we can, especially if the aerial might have been damaged. If you can't measure SWR then the range check gives a guide to efficiency especially if range suddenly drops for all of your models. SWR meters are available for 2.4GHz but they require the meter to be placed in the feed wire. I suppose that could be done if you change the aerial fitting on your transmitter to an RP-SMA one that allows the aerial to be unscrewed but I have not read anything suggesting that and haven't tried it. You might remember that I mentioned RP-SMA aerial bases in a previous article on aerial repair (see *Resources*).

Here there be dragons. If you read or watch the information put out by radio amateurs (hams) you will discover that aerial matching is in reality much more tricky. It can even involve the use the square root of minus 1, called *i* or *j*. I have added the video *Standing Wave Ratio Explained* in *Resources* if you're interested in learning more.

Aerial Tuning

When you did the rope experiment you got one or more standing wave loops. A wave goes up to a maximum in one direction, back to zero, then to a maximum in the other direction then back to zero again. The distance from the first node to the third is called wavelength, measured in metres (m). The length of an aerial must be correct for the frequency and wavelength of the signal. For our transmitters the frequency will usually be 2400 or 900MHz. The corresponding wavelengths in air are 125 and 330 mm. In a metal the wavelengths are roughly two-thirds of these as the signals travel more slowly so the wavelength is less. Some people still use 35MHz in the UK, giving a wavelength of about 8.6m. That is why these transmitters have long aerials.

A radio control aerial will effectively be one quarter wavelength. This is because the transmitter circuitry will provide maximum voltage at one end – an antinode – and the far end will be a node. Usually an aerial is made up from two quarter wave parts going in opposite directions. This is called a dipole. You see these in a long television aerial, called a yagi. On such aerials there are other similar size rods parallel to the dipole which also have currents induced in them by the transmitted TV signal. It makes the aerial very directional, which helps to exclude interference from other sources, and they amplify the signal read by the dipole. Some free flight flyers fit their models with location transmitters and use dipole yagi aerials to follow the signal to a lost model. In game reserves tracking of endangered animals is done in the same way. Our transmitter aerials cannot usually be dipoles, though some 900MHz ones do appear to be.

Experiment №4

If your transmitter can display SWR you can try this. Note the number when in normal use. Then grab the aerial with your hand. This will change the impedance of the aerial but not the feedwire. SWR will go up, perhaps as high as 18. Don't hold it for long as the bounced and wasted energy might harm the transmitter circuitry. Rather confusingly a FrSky transmitter pretends that it measures SWR. Though it measures the same things it does it in a different way that gives perfect transmission the value zero not one. They have now renamed it Relative Antenna Status (RAS) and you can find it on page seven of Radio Setup on a Taranis X9D.

Electromagnetic Waves

When electricity flows up a wire it does two things. The current creates a magnetic field, labelled B in Picture 6. The charge/voltage creates an electric field, labelled E in the same diagram. These are at right angles to each other and collectively known as electromagnetic waves. They rise and fall exactly in sync, known as being in phase.

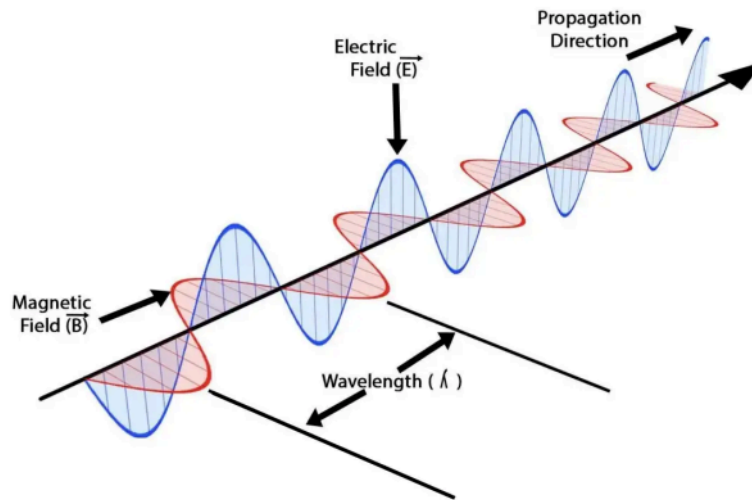

Picture 6 (credit: brainly.in)

The maths behind electromagnetic waves was finally codified by James Clerk Maxwell's equations. It is not a book for the fainthearted, but if you are mathematically inclined try *Div, Grad, Curl, and All That: An Informal Text on Vector Calculus* by H. M. Schey.

James Clerk Maxwell (1831–1879)

Maxwell was born into a prosperous Edinburgh family. From the age of three he was one of those children always asking 'why'. Or in his case, 'What's the go o' that?' After an unsuccessful period with a home tutor, he was sent to Edinburgh Academy. Even here he was thought odd but he did not seem to care. He found study at Edinburgh University rather easy and spent a lot of time experimenting there and at home including light polarisation. He used a gelatine block and polarised light to study stress patterns in solids, now done using perspex (plexiglass) sheets. I previously described an article in Scientific American showing how they studied stresses in Chartres Cathedral using perspex shaped the same as the building. After spells at Cambridge, Aberdeen and King's College, London he stayed for a while at Cambridge, where he set up the Cavendish Laboratory and investigated colour and kinetic theory. His greatest achievement was to draw together the work of Faraday, Ampere, Gauss and Coulomb and write a set of equations that described electric and magnetic fields. His ability in

maths was proved at Cambridge where he became 'Senior Wrangler' in 1854.

Transmission through Space

Let's imagine two vertical bits of wire some distance apart. One transmits and the other receives. The transmitter sends out electromagnetic waves like those above – magnetic and electric fields. For simplicity I just show an electric field in Picture 7.

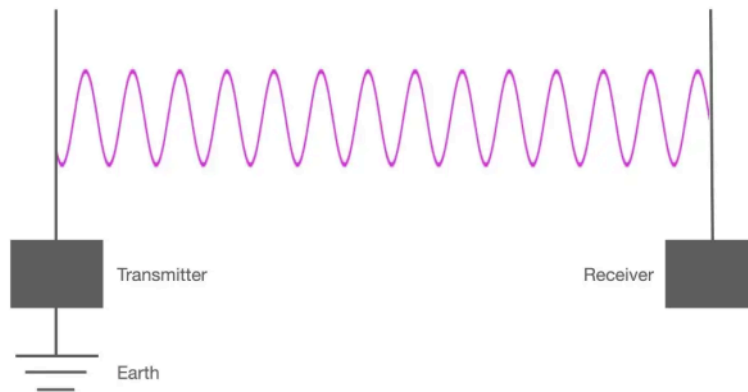

Picture 7 (credit: Peter Scott)

The transmitter and receiver aerials must resonate at the same correct frequency. That will depend on their lengths, how they are arranged and the circuit they are connected to. In practice aerial designs in our transmitters are complicated, not just a simple wire, especially when wholly enclosed in the case. The transmitter pushes electrons up and down the aerial, creating the travelling electric field. When it arrives at the receiver this field pushes electrons in an identical way in the aerial wire. The receiver circuitry amplifies and decodes the signal. Some receivers, most notably FrSky ones, will, using telemetry, tell you the strength of the signal received by the receiver. For FrSky it is called Received Signal Strength Indication (RSSI).

Hertzian Transmission

When in 1887 Hertz sent the first radio signals, the transmitter was a huge spark that sent a signal up a wire. The receiver was a metal loop

with a gap across which a spark appeared as shown in Picture 8.

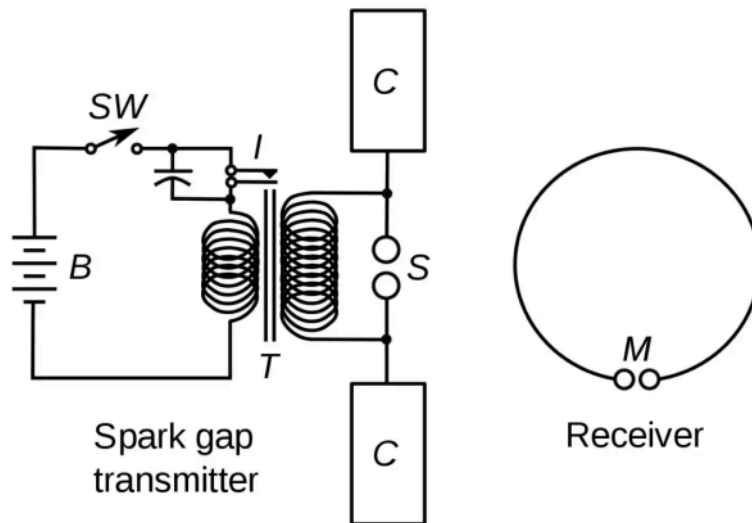

Picture 8 (credit: Wikimedia)

Heinrich Hertz (1857–1894)

Hertz's mother had the delightful maiden name of Pfefferkorn. His was a prosperous and upper-class family. He studied science and engineering under illustrious tutors. As professor at Karlsruhe and Bonn Physics Institute he experimented with spark gap transmitters of electromagnetic waves, including refraction and polarisation. He said radio waves were a useless phenomenon but showed that they were transverse waves travelling at the speed of light. He studied meteorology, particularly the effect of moisture in the air and, not directly relevant to us, the photoelectric effect. The SI unit of frequency is named after him.

In 1894 Oliver Lodge, at a memorial lecture about Hertz, demonstrated a detector that was a tube of silver flakes called a coherer, shown in Picture 9. When the spark signal was received the flakes clung together forming a circuit that switched on a sound or moved a meter. They were broken apart again by vibration. This sort of radio transmission only gave an on-off signal so could only be used for messages in morse code.

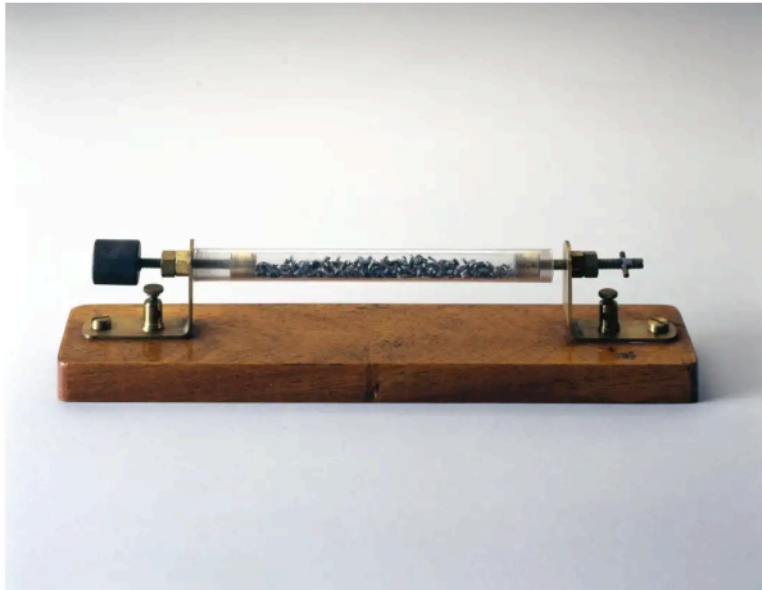

Picture 9 (credit: Science Museum Group)

You could build a spark coherer but it would be illegal now as the signal it needed occupied a wide range of the radio spectrum. Men in dark suits and sunglasses would soon be knocking at your door as television pictures collapsed, car engines stopped and garage doors opened and closed all by themselves.

The internationally recognised Indian scientist Chandra Bose designed a mercury 'self-recovering coherer' in 1896 that required no vibration. Marconi used a similar design but who was first is uncertain. He also invented a diode signal detector which became commonly known as a cat's whisker.

Sir Jagadish Chandra Bose (1858–1937)

Bose was born in the Bengali city of Munshiganj, whilst India was under British government. It is now in Bangladesh. He is less well known than many scientists but he did pioneering work in radio, semiconductors and plant structure and nervous function. Bose's father was a leading civil servant and an active member of a branch of Hinduism. He was keen that Bose should know about his native language and culture before moving to English for his studies. After schooling in Calcutta (now Kolkata) he entered the university there graduating in 1879. He studied medicine at London

University but quit because of ill-health possibly due to the body preservation chemicals. He moved to Christ's College Cambridge to study the Natural Sciences Tripos under distinguished scientists including Rayleigh and Dewar and also later graduated from London Universities .

From there he joined the University of Calcutta as a professor of physics. As a protest against the fact that Indians were paid much less than white academic staff he refused a salary for several years until they were equalised. Despite this racial bias and a lack of money he worked on microwave radio waves and was the first to use a semiconductor junction to detect waves. These became known as cats' whiskers. Other inventions included devices we still use such as waveguides, horn aerials, radio lenses and polarisers. His work went up to 60GHz. The IEEE named him one of the fathers of radio science.

Using sensitive plants such as *Mimosa Pudica* he investigated the nervous systems of plants and compared their responses to physical stimulæ with those of metals.

In 1917 he founded Bose Institute as Director, a premier research institute of India and one of its oldest. It was the first interdisciplinary research centre in Asia. He remained there until his death. He is not connected with the Bose loudspeaker company.

Early Radio Control

Radio engineers soon learned to send their signals at a particular frequency. They did this by adding tuned circuits rather like the way that instrument strings or pipes store energy at their resonant frequencies. However they were far from perfect so the signal spread over a band of nearby frequencies. As a result only one radio control model could be in the air at the same time. Only when the tuning was sharpened using crystals were six, and then twelve, bands possible on

the 27MHz then used in the UK. Each band was given a colour and flyers clipped a suitable coloured flag on their transmitter aerials. Sensible flyers still avoided using a band next to another already in the air.

Modulation

Connecting a transmitter to a receiver is only the beginning. We now have to send our control signals to the receiver and telemetry data back to the transmitter. The wave that is sent by the transmitter is called a carrier wave. It is this wave that is 2.4GHz, 900MHz etc. To send out instructions we must alter the carrier, called modulation. There are several ways of doing this but here are two. You can vary the carrier in its height (amplitude), called amplitude modulation (AM), or frequency, called frequency modulation (FM). For FM the changes in frequency are small to avoid widening the frequency band too much. The disadvantage of AM is that general electrical noise also alters the amplitude at random. You can hear this as background hiss on old AM radios. FM is almost completely immune to this noise.

For radio control the information we need to send is very simple. It is a series of rectangular voltage pulses that vary between 1ms (millisecond) to 2ms depending on the position of the control stick, switch or rotary. Each pulse in the series operates one servo, undercarriage or throttle. This is called Pulse Width Modulation (PWM). The carrier flips from one state to another and back again. The time between flips is the length of the servo pulse. This is best shown in diagrams Pictures 10 and 11.

Amplitude Modulation (AM)

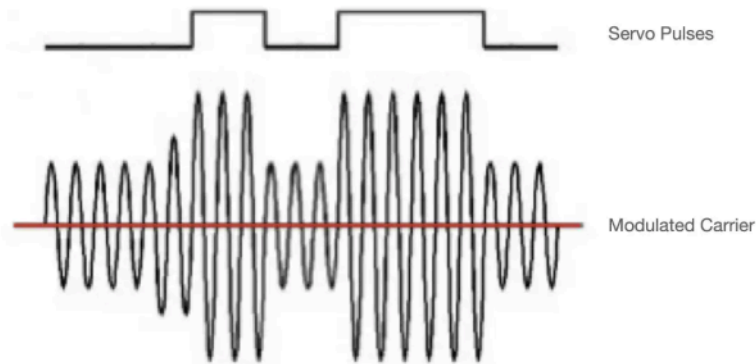

Picture 10 (credit: quora.com)

Frequency Modulation (FM)

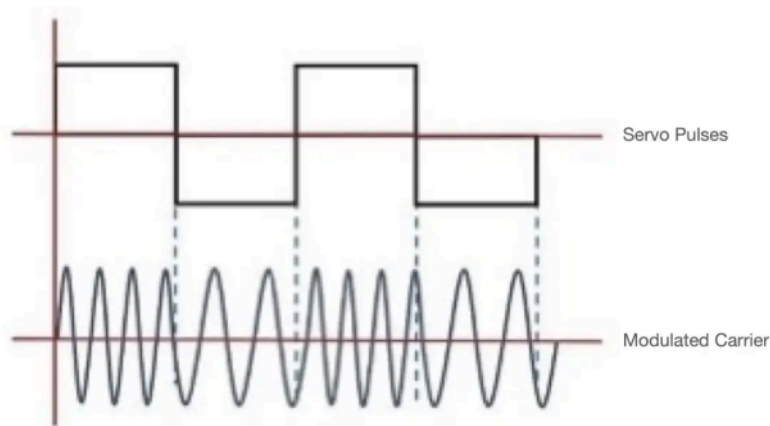

Picture 11 (credit: quora.com)

▶ Experiment Nº5

You can sort of repeat Hertz's experiments. Find a 9V battery such as a PP3, a metal coin and an old portable AM radio. Hold the battery close to the radio, especially the aerial if it has one. If you then tap the coin across the battery terminals, you hear clicks or other noises from the radio speaker resulting from the tiny sparks. The reason it won't work with an FM radio is that the circuitry ignores changes in wave amplitudes, and only responds to frequency changes. This is why there is no background noise.

Rectangular Waves and Fourier Synthesis

The nearer a wave gets to having right-angled corners the more problems it causes. A mathematician called Joseph Fourier showed

that any wave shape can be built up from a series of sine waves of different frequencies and amplitudes. Rectangular waves are built up from the odd harmonics. You can see that intuitively from Picture 12. The waves that add up must rise and fall at the rising and falling edge of the rectangular wave. Only odd harmonics do that. In between the waves average out to make the horizontal line.

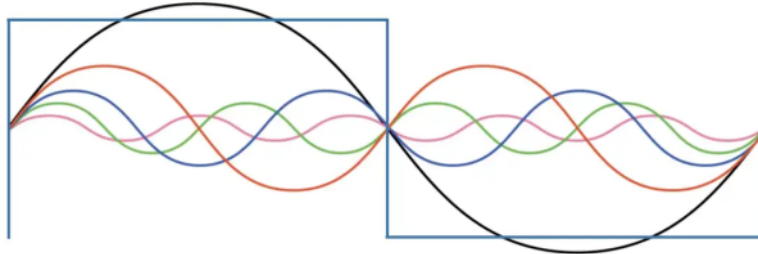

Picture 12 (credit: Dynamic Therapy Ltd.)

To get closer and closer to a right angle you need higher and higher overtone frequencies with steeper leading and trailing edges and for a perfect right angle the series must be infinite. So even a low frequency rectangular wave will include very high frequencies that can cause interference to other equipment. Fortunately the reactance in wires increases with frequency so the highest frequencies are suppressed. The effect is that the corners of rectangular waves are rounded off. You can also use electronic filters that cut off the higher frequencies, again altering the signal shape.

Fourier's idea is used to compress digital sound and picture files using jpeg. The process used is so mind boggling that it is out of place here. My article on the subject is on my website under the *Audiovisual* section.

Inverse Square Law

This was first discovered by Sir Isaac Newton when studying gravity and later confirmed by Coulomb for electric forces. Any energy field spreads out from its source. The area of the sphere over which the energy is spread increases with the square of the distance away from the source ($4\pi r^2$). So the strength of the field goes down with the

square of the distance. This is one factor that determines the range of our transmitters. Others will be discussed later, namely polarisation, diffraction and absorption.

Sir Isaac Newton (1642–1726)

Newton was a leading worker in many fields. In mathematics he invented calculus. During his self-isolation from the plague in rural Lincolnshire, he connected the fall of objects such as apples near the earth with the motions of planets and the moon by analysing gravitational data and devised his equation. He made advances in the fields of movement, telescoping and colour. Above all he asserted 'satis est', 'it is enough'. If the maths works it is proven. He ran the Royal Mint for some years and tracked down influential counterfeiters, acting as his own private eye. He was religious though unconventionally so. In those days science was not disconnected from religion and superstition as it is now, and in his later years he took up alchemy. He was possibly on the autistic spectrum and though he lived long for the time his occasional irascibility and his death might have been caused by the mercury he absorbed during his chemical experiments. He could be vengeful, especially towards Robert Hooke and Gottfried Leibnitz. His name is given to the SI unit of force the *newton*, delightfully being the weight of a medium sized apple.

Polarisation

Waves are the movement of a medium. With water and EM waves like light the medium vibrates at right angles to the direction of movement as shown above – transverse waves. When light is produced, for example by the sun, the sideways vibrations are in all directions. We can remove some of these directions by polarisation. For example when light reflects off a surface such as water or a wet road it becomes polarised parallel with the surface as shown in Picture 13. The other vibrations are absorbed by the surface.

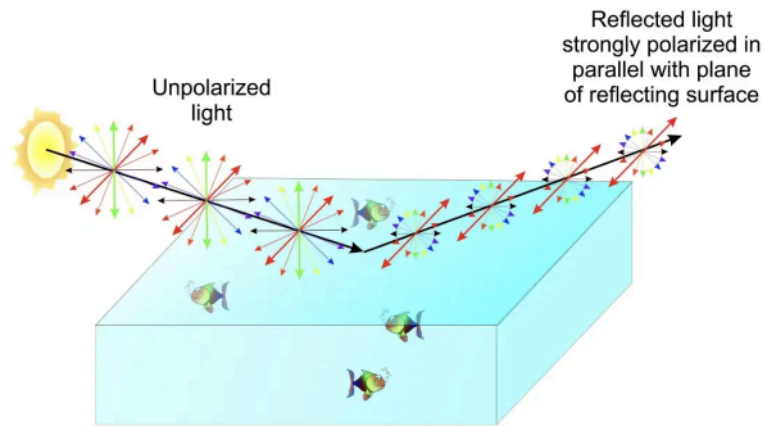

Picture 13 (credit: hackaday.io)

Glasses with polarised lenses only allow one polarisation direction through. Vertically polarised lenses block light reflected off water or the road and so reduce glare. You can still see surrounding things lit by the unreflected and unpolarised light.

▶ Experiment №6

Find two pairs of polaroid glasses, such as sunglasses. If you only have one pair see if you can pop one lens out replaceably. Look through two lenses, one behind the other, as shown in Picture 14. Rotate one lens and you will see the scene getting light and dark.

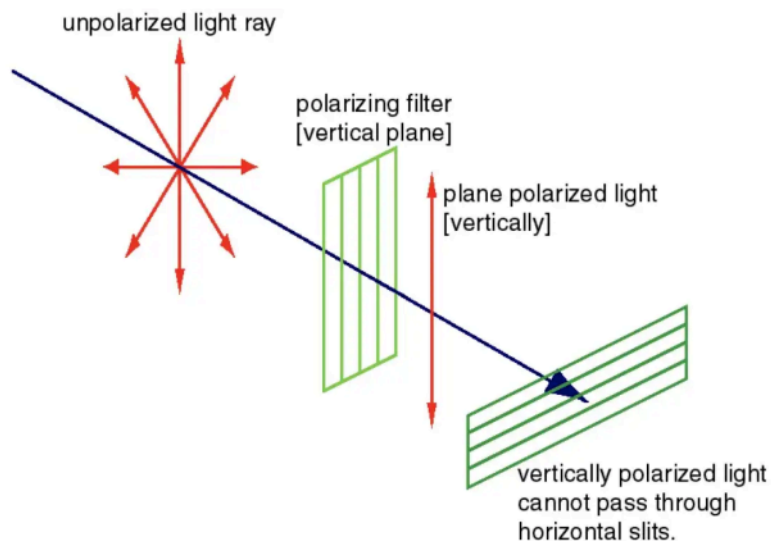

Picture 14 (credit: thestudentroom.co.uk)

Why Polarisation Is Important for Us

Hertz showed that the radiation from our transmitters is polarised. The problem is that our models don't stay still. A receiver aerial wire will move from vertical to horizontal and in some orientations will get a much lower signal. That is why it is sensible to have two receiver aerial wires orientated differently such as horizontal and vertical or even better to have a second, slave receiver with aerial wires differently arranged from the master.

Diffraction

When I marked Physics public examination papers, diffraction was one thing that students regularly got badly wrong. I could never understand it. I stress humbly that these were not my students. Diffraction is very simple. When a wave goes past the edge of a barrier it spreads out round it. This means there is never a sharp shadow, and why a beam will spread at its edges however sharply focussed it is to start with. I know someone who has his own observatory. He measures the distance to the moon using a red laser bouncing off the half-cube reflectors kindly placed on the moon by NASA. Laser beams don't diffract and spread as much as normal light but he still has only a tiny amount reflected back to his sensors.

In Picture 15 you see how waves bend around edges. A small gap between two barriers behaves like a point source producing near circular waves but of much lower energy as most of the wave energy is absorbed or reflected by the barriers.

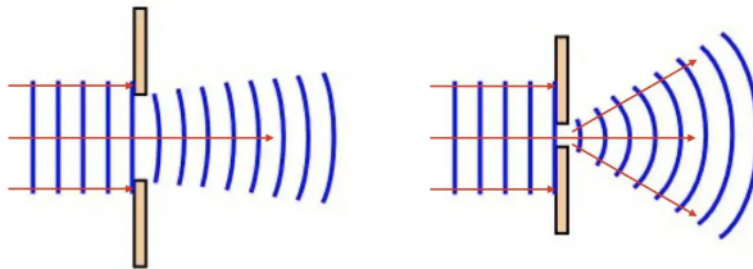

Picture 15 (credit: quora.com)

The shorter the wavelength of waves the less they diffract. Suppose you are standing a little way back from the edge on a cliff by the sea.

You can still hear the waves. You won't hear the high frequency hissing sounds but will still hear the deep bass rumbles. It is also why 35 or 900MHz radio signals are less affected by hills, trees or other barriers as they bend better than 2400GHz.

Why Is This Important to Us?

It depends on where you fly. If you are likely to fly your model briefly behind a barrier of some sort, like a hill peak or a control tower, the longer wave 900MHz frequency might be best for you. In open spaces its only advantage is much greater range.

When there are two gaps, or a series of them equally spaced forming a 'grating', strange effects happen. Each gap, or slit, produces a pattern of semi-circular waves. They mix and where both amplitudes are high they add together and produce a bright patch, the solid red lines in Picture 16. Where a peak meets a trough they cancel, shown by the duller dotted lines. A pattern of bright and dark patches, called fringes, is produced. Waves of shorter wavelength produce fringes that are closer together, which is the subject of the next experiment. Thomas Young was the first to investigate diffraction patterns.

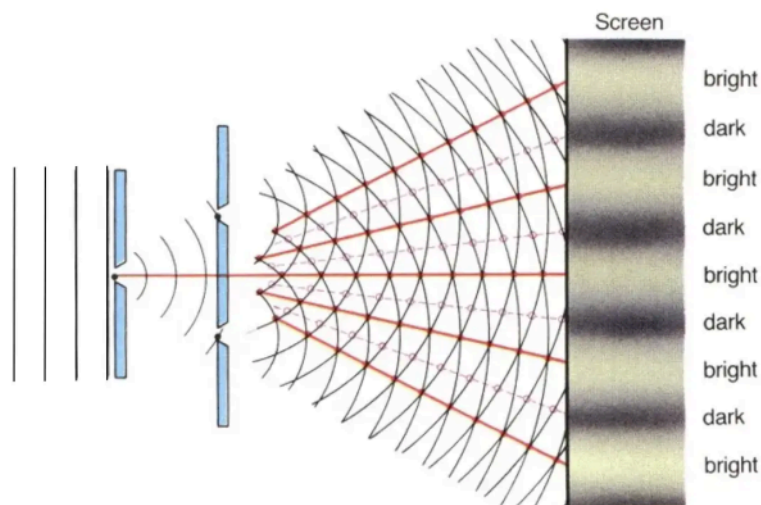

Picture 16 (credit: physics.stackexchange.com)

Thomas Young (1773–1829)

There was very little that Young did not contribute to. He was described as 'the last man who knew everything', and his work was used by many later scientists. He was born to a prosperous Quaker family, the eldest of ten children. He studied medicine in Britain and Germany and then inherited an estate that gave him a living. For our purposes his work on the wave theory of light is the most important, though his name is attached to *Young's Modulus* that predicts how materials change under force and Young-Laplace capillary effects and surface tension. Young asserted that light was waves and demonstrated diffraction and interference. Newton thought that light was particles which caused hilarity until the twentieth century when photons were discovered and it was shown that light could be either waves or particles depending on how you measured it.

Experiment N°7

Find a used compact disk. Line it up so light is reflected from a window or an old-fashioned filament lamp. LED lamps won't work as they don't produce a full range of colours. You will see rainbows. Why? The burned or pressed data lines form a grating. As explained above, blue light has a shorter wavelength so its fringes are in different places from red. The colours are separated into a spectrum.

Experiment N°8

Hold two fingers up in the air so there is a very narrow gap. Look through the gap at a nearby lamp. You will see a blurred shadow between the fingers with lines. This is due to the light diffracting and producing fringes.

Absorption

Waves from our transmitters are absorbed by the environment. What you might not know is the effect of water in the air. Microwave ovens

work at about 2.4GHz – the same as our transmitters. Why? It is because water absorbs that frequency efficiently and the heated water content heats the food or drink. So when it is misty not only should you not let the model get too far away but you should remember the range might be less.

Another absorption risk is the material that fuselages are made from. Carbon fibre is excellent as a building material, but carbon is conductive and will absorb, and so block, the signals from reaching the receiver.

Experiment Nº9

Here's a tip using absorption for FrSky flyers. If you land a model out of sight you might be able to locate it using the RSSI signal from the receiver. Obviously this only works if the landing wasn't hard enough to disconnect the battery, for example if you land in a hedge or your fail safe settings are perfect. Go towards where you think the model is. Turn around 360 degrees while looking at the RSSI reading. It will drop to near zero when your body is between the transmitter and the model. The maximum signal strength will give you an idea of the distance using the idea of the inverse square law.

Polar Diagrams

Confusingly these are different from polarisation. A transmitter aerial does not send out waves equally all the way round. For example it sends almost none along its axis, probably vertically upwards. That is a third good reason for not letting models get overhead. The other two? Safety and club rules. Even on a horizontal plane the distribution is uneven, for example due to absorption by your body. For aerials in general you can plot their transmitter power and receiver sensitivity on a polar diagram like the one in Picture 17.

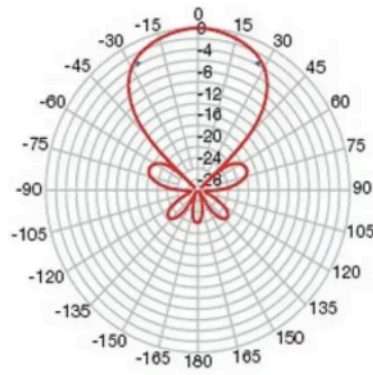

Picture 17 (credit: aerialsandtv.com)

Picture 17 is just an example and does not apply to our transmitters. In Picture 18 are the polars from the published manual for the 2.4 and 900 aerials on the twin-frequency FrSky Tandem range of transmitters and aerials.

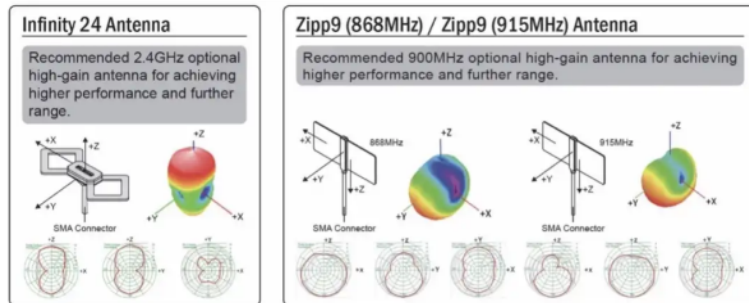

Picture 18 (credit: frsky-rc.com)

The Famous Four

These are the four scientists whose work contributed most to Maxwell's equations:

Michael Faraday (1791–1867)

Faraday was from a modest family and self-educated. He was apprenticed as a bookbinder and read the books he was working on. He attended Humphry Davy's Royal Institution (RI) and Royal Society lectures and gave Davy a three hundred page bound book based on his notes on the lectures. As a result Davy got him a job at the RI as a technician. He was a superb experimenter even though poor at maths. Two significant areas of work were the magnetic effect of a current and the use of currents in chemistry

called electrochemistry and electrolysis. He had two units named after him, the SI capacitance unit the farad and the now outdated faraday unit of charge which was replaced by the coulomb. He refused to work on chemical weapons for the Crimean War. His work was later used by James Clerk Maxwell. On BBC television, the RI continues to this day his Faraday Lectures started in 1825, now renamed *Christmas Lectures* and aimed at young people (see *Resources*).

Charles-Augustin de Coulomb (1736–1806)

Coulomb was born into a prosperous family and was educated in Paris. After financial problems for his family he joined the army as an engineer. After inventing a torsion balance based on the force produced by twisting a wire, he then used the balance to study the inverse square law of the forces between two charged objects and realised that static charge is on the outside of an object, even conductors. Later works included investigation into the forces between currents, or 'electric fluids' as he called them, but he did not make the connection between charge and current. He also investigated what we would now call 'tribology', the science of friction and lubrication. The SI unit of charge, the coulomb, is named after him. His work was later used by James Clerk Maxwell. His name is inscribed on the Eiffel Tower. He sensibly retired to the country at the start of the French Revolution.

Carl Friedrich Gauss (1777–1855)

Born to uneducated working class parents, Gauss showed maths ability from the age of three. By the time he was twenty-one he was seen as a prodigy and had published his first book. His parents did not even know his birthday but he worked it out when he devised a method to find the date of Easter. The Duke of Brunswick was impressed by him and paid for him to go to university. He collaborated with his professor Wilhelm Weber over magnetism. His cgs (centimetre, gram, second) 'gaussian equations and units' were used until the introduction of SI – Le Système International

d'Unités – and his magnetic work was later used by Maxwell in his set of unifying equations. He was a perfectionist and wrote down little about his discoveries. He was a great believer in the pleasure of learning. As soon as he had mastered a subject he left it to start on another. He clarified the Fast Fourier Transform. It is said that someone challenged him with a classic maths puzzle that often fools maths experts due to mind set.

“A wasp cannot make up its mind which of two walkers to sting. They start a 1000m apart and each walks at 2m/s towards the other. The wasp goes back and forth directly from one to the other at 5m/s. How far does it fly before the two walkers meet and he can sting them both?”

Mathematicians use integration of the ever-decreasing separation. Non-mathematicians will realise that at 4m/s combined speed the walkers meet after 250s and the fly has flown 1250m in that time. To everyone's surprise Gauss instantly gave the correct answer. When someone said, 'We thought you'd integrate it to get the answer', he replied, 'What other way is there?' He had done the integration in his head. His name is still used for normal distribution of data, though the gauss for magnetic field strength in cgs units has been replaced by the SI unit, the tesla.

André-Marie Ampère (1775–1836)

André-Marie Ampère was born to a prosperous French family. He was educated using the principles of Rousseau. These were effectively self-teaching and learning by experiencing nature, which is a good start for a scientist. He used his father's extensive library of enlightenment books. Despite the lack of formal education he became a teacher, then a professor of mathematics at a top French school and then professor in experimental Physics. He is best known for investigations of magnetic fields around wires carrying currents. Maxwell used his work and named him 'the Newton of Electricity.' His name is used for the SI unit of electric current. His father was guillotined during the French Revolution. At least

Ampere didn't suffer the same fate, unlike Antoine Lavoisier the chemist.

And finally...

Neils Bohr (1885–1962)

A Danish physicist who will no doubt pop up again in a future article. He was key to quantum physics and won a Nobel Prize. I learned a delightful fact about him recently. The Carlsberg brewery wanted to give him an additional reward for the Nobel. They gave him a house next to the brewery with a permanent pipe from it leading to a tap (faucet) over his kitchen sink. Beer on tap! Great parties!

That's it for this month. Next month, *Part V: Visual Acuity*. As usual, if you have any questions, please get in touch by leaving a comment in the *Responses*  section below. Until next time, thanks so much for reading.

©2023

Resources

- *On The Shoulders of Giants* – The Wikipedia links for those historical figures mentioned in this article and on which the short, italicised bios are based: [André-Marie Ampère](#), [Neils Bohr](#), [Jagadish Chandra Bose](#), [Charles-Augustin de Coulomb](#), [Michael Faraday](#), [Carl Friedrich Gauss](#), [Heinrich Hertz](#), [James Clerk Maxwell](#), [Isaac Newton](#) and [Thomas Young](#).
- [2.4GHz Radio Bind Technical Details](#) Thread from *RCGroups*. – “I’m trying to understand a few details of 2.4GHz RC technology. I’m interested in the details because I would like to do some DIY transmitter work...”
- [Antenna](#) from Wikipedia. – “In radio engineering, an antenna or aerial is the interface between radio waves propagating through

space and electric currents moving in metal conductors, used with a transmitter or receiver...”

- [*Div, Grad, Curl, and All That: An Informal Text on Vector Calculus*](#) by H. M. Schey on AbeBooks (for example). – “widely renowned for its clear and concise coverage of vector calculus, helping science and engineering students gain a thorough understanding of gradient, curl, and Laplacian operators...”
- [*Electromagnetic Wave Equation*](#) from Wikipedia. – “The electromagnetic wave equation is a second-order partial differential equation that describes the propagation of electromagnetic waves through a medium or in a vacuum...”
- [*Electromagnetism*](#) from Wikipedia. – “In physics, electromagnetism is an interaction that occurs between particles with electric charge via electromagnetic fields...”
- [*Repairing a Transmitter Aerial*](#) by the author. – “I decided to replace the standard aerial with a removable one that screws on. For this I had to install a different fitting called an RP-SMA connector. SMA is an abbreviation for SubMiniature version A...”
- [*Senior Wrangler*](#) from Wikipedia. – “the top mathematics undergraduate at the University of Cambridge in England...”
- [*Standing Wave Ratio*](#) from Wikipedia. – “a measure of impedance matching of loads to the characteristic impedance of a transmission line or waveguide...”
- [*Standing Wave Ratio Explained*](#) by Pulsecommunications on YouTube. – An excellent account of the subject. However, note the speaker uses a presumably Australian pronunciation of co-axial as ‘co-ax-eye-all’, which might catch the viewer out at first.
- [*SWR and Transmitters: Friends or Foes!*](#) – “You just ... made some changes to your antenna system to squeeze out a bit more signal and hooked the feed line into your swr meter. Now it’s time to decipher those swr readings...”
- [*The Royal Institution: Christmas Lectures*](#) – “the world’s leading science lectures for young people and have been inspiring children and adults alike since 1825...”

- [*Understanding SWR by Example: Take the mystery and mystique out of standing wave ratio.*](#) by Darrin Walraven, K5DVW. — “It sometimes seems that one of the most mysterious creatures SWR vs Reflected Voltage...”
- [*Peter Scott*](#) — The contact page on the author’s personal website. This is also where you can find the author’s article on jpeg compression in the *Audiovisual* section.

Also by the Author

- [*Electricity for Model Flyers*](#) — The author’s complete, highly regarded series presented on the pages of the *New RC Soaring Digest*.
- [*Cellmeter 8*](#) — “What’s on offer for this economical battery meter and servo tester? Quite a bit, actually...”
- [*The Fine Art of Planking*](#) — “The time-tested method for moulding strips of wood into an organic, monocoque structure...”
- [*The Complete Peter Scott*](#) — All of the author’s articles published in the *New RC Soaring Digest*.

Read the [*next article*](#) in this issue, return to the [*previous article*](#) in this issue or go to the [*table of contents*](#). A PDF version of this article, or the entire issue, is available [*upon request*](#).

Soaring the Sky Podcast



E093: Monkeys, Coconuts, Field Fires and John Denver | An Interview With Don Ingraham

Our ninth instalment of this ongoing series where we select and present episodes from Chuck Fulton's highly regarded soaring podcast. See Resources, below, for links where you can find Soaring the Sky, or simply click the green play button below to start listening.
— Ed.

Don Ingraham was living in Minneapolis when he was bitten by the soaring bug in 1993 at age 39. Thanks to the tutelage of Bob Wander, by age 40 he had soloed, earned a PPG (private pilot, glider) certificate and purchased a *Jantar* Standard.

Over the next couple of years he flew the *Jantar* to more than a dozen Minnesota state soaring records and kept busy during the winters refinishing it in gelcoat — with much phone advice from George Applebay. Don started flying contests in it in 1996 and moved up to a *Discus* in 1999. His wife, Kathy, was always willing to track him down, trailer in tow, when he couldn't make it home from a cross country

flight. He won the Hilton Cup in 1999 and got to make a dream come true – meeting top pilots and flying different gliders from the Hilton Ranch for ten days straight.

A few years later, in 2003, he asked Kathy what she thought about the idea of going into business running a commercial glider operation. He explained the six-figure salary would be gone and there was a very steep and potentially perilous learning curve. And it would take a big chunk of money. And he had no idea how to do it. And they had two toddlers, Chase (2) and Ali (4). Kathy paused for a moment, then asked how he would feel, years from now, looking back, if he went back to the stable-yet-now-soul-crushing computer world and never tried to start his own business. Don said he'd feel like a frumpy, cowardly, wimpy loser. Kathy said she didn't want to be married to that guy, so game on!

Don and Kathy built a website, bought a tow plane (Socata *Rallye* 235E) and a glider (Grob 103 *Twin II*) and opened the doors of Cross Country Soaring, Inc. in Faribault, Minnesota in 2004 (see *Resources*). They now operate a second Grob 103 and a have a winch. He is beginning his 17th year in operation. Check it out with the link in *Resources* below.

Bob Wander was a key factor in Don's success in pursuit of life in the sky and they have remained good friends. Bob asked Don to write a book based on a talk he delivered at the Sport's Aviation Conference in Minneapolis in 1996. That book, *The Final Four Minutes – Landing Out*, is now available for a song! Again, see *Resources* below for the link.

©2021, 2023

Resources

- [Cross Country Soaring, Inc.](#) – “We are a commercial glider operation based at the Faribault Municipal Airport, about 35

minutes south of Minneapolis on I-35W. We operate from April through October...”

- [Bob Wander's Soaring Books and Supplies](#) – “Here at bobwander.com, sixty bucks will buy you a number of books and deliver them to your door as well...”
- [George Applebay](#) – “The United States Southwest Soaring Museum exists because of the vision and efforts of George Applebay...”.
- [Soaring the Sky](#) – “an aviation podcast all about the adventures of flying sailplanes. Join host Chuck Fulton as he talks with other aviators around the globe”. You can also find Chuck’s podcast on [Instagram](#), [Facebook](#) and [Twitter](#)

Subscribe to the Soaring the Sky podcast on these preferred distribution services:

Condor Corner



Introduction

See this month's In The Air column (link in Resources, below) for the background as to how we managed to convince Scott to make this great series available to readers of the New RC Soaring Digest. Suffice to say, for now, that the original version of this article first appeared in the January 2022 issue of Soaring magazine. — Ed.

Prologue

From April of 2010 through September of 2014, Frank Paynter and I authored an article for *Soaring Magazine* called *Condor Corner*. Frank was an avid competition soaring pilot who had used *Condor* to develop and polish his racing skills and was interested in helping others do the same. I was a relatively new Certified Flight Instructor for Gliders (CFIG), and having come from the educational community, realized the benefits simulation-based glider flight would provide the soaring community, including not only improved flight training, but also an increased level of safety through flight proficiency, greater

efficiencies of time & money and an exciting venue for promotion of the sport.

In the spring of 2018, I was contacted by Eric Bick, the then-current editor of *Soaring*, and asked to help relaunch a long-running article in *Soaring* called *Teaching Soaring*. My contributions to that series of articles ran from June of 2018 through November of 2021, and while the *Teaching Soaring* article helped advance the issue of glider flight training, it lacked the broader appeal of the original *Condor Corner* article.

Redux

To that end, I proposed a revival (redux) of *Condor Corner* to *Soaring's* new editor, David Hart and he graciously agreed to begin its publication. The format was a monthly submission of no more than one page, including an image or two, introducing or reminding the SSA membership of a new or existing application and/or benefit of flight simulation. Each article's topic fell into one the larger categories of interest including flight safety, flight training, flight proficiency, advanced skill development (such as cross country flight, competition, aerobatics, mountain flying, ridge flight, wave flight, launch methods), *Condor* features, tips & tricks and using the software to promote the sport.

A Broader Perspective

I first began publicly advocating for the use of flight simulation at the 2008 SSA convention in Albuquerque. The ensuing years have seen a slow but steady increase in simulation's adoption within the soaring community. So, in addition to my contributions, I am inviting SSA members, clubs, and commercial operations to contribute to the content of the article by contacting me regarding their positive experiences using glider flight simulation.

Next Month

In the next instalment of this column, I will talk about how *Condor* helped the soaring community thrive during the recent pandemic, which was also generally instructive for a variety of situations where flight simulation is required to substitute for actual stick time.

Thanks for reading, and if you have any questions, please feel free to leave in the *Responses* section below, which you can access by clicking the . You may also contact me through my website which is linked below in *Resources*.

©2022, 2023

About the Author

Scott Manley has an undergraduate degree in secondary education and more than 45 years of teaching experience. He provides year-round simulation-based glider flight instruction at-a-distance (*Condor/Skype*) to glider rating candidates nation-wide, and consultation services to flight training organizations and individuals interested in adopting this paradigm. He holds Certificated Flight Instructor privileges for the glider category. The back of his pilot certificate reads: Commercial pilot: airplane single-engine land & sea; instrument airplane; glider.

Resources

- [*Simulation-based Glider Flight Education*](#), the author's website. – “to provide you with the information and resources you need to self-manage the flight training and aeronautical knowledge development required to qualify for a Private Pilot Certificate with a Glider Category...”
- [*Condor*](#) – “simulates the complete gliding experience on your computer. With it you can learn to fly gliders and progress up to a high level of competition skill. The core of the simulator is the state of the art physics model and advanced weather model aimed at soaring flight.”

- [Soaring Magazine](#), the official publication of the Soaring Society of America. – “each issue brings you the latest developments on safety issues, delightful accounts of individual soaring accomplishments, a sharing of ideas and experiences, tips from the great soaring pilots of our times, and...”
- [Soaring the Sky Podcast](#) – The episode from the January, 2023 issue of the New RC Soaring Digest which features Scott Manley, the author of *Condor Corner*, as a guest.
- [In The Air](#) by RCSD Managing Editor Terence C. Gannon. In this month’s column, the ‘broadened editorial footprint’ – and the reason behind it – is described. It will have the New RCSD running regular features on the subject of glider flight simulation as well as other RC soaring *adjacent* subjects.

Condor image above the title provided by the author. Read the [next article](#) in this issue, return to the [previous article](#) in this issue or go to the [table of contents](#). A PDF version of this article, or the entire issue, is available [upon request](#).

Five Minute Fixup



The 'fixed up' Solution XL.

Frequent RCSD Contributor Marc Panton Kicks Off a New, Informal Series

Assuming that readers jump on the opportunity, the Five Minute Fixup series articles are intended to be short – as in five minutes^t reading time – that focus on saving a sad castoff from the rubbish tip. We can't think of a better person to start the series off than Marc. We also ask readers to start thinking about their own Five Minute Fixup article – we're sure there are plenty out there! – Ed.

^tAt least it was 'til the editors added all their 'doodads'.

An interesting glider popped up recently on the *For Sale* boards I frequent: a 4m Simprop *Solution XL*. I have an old 2.8m *Solution* that's had a hard life but still goes well on the slope, so the 4m immediately got my attention. More interesting was the *SATS* system (see *Resources*) which blows air from a row of tiny holes in the upper wing skin about one-third chord. The purpose is to disrupt the laminar flow

into turbulent flow before it separates, much like turbulator strips do (also see *Resources*).

After a few emails and some photos, the deal was done and I collected a 4m glider that some might class as 'slightly tatty' but overall, pretty solid. The hinges with original tape were well yellowed. The ones that weren't were covered in white duct tape. Underneath, there was the old yellow tape still! Aerodynamically, things were not helped by the 1–2mm (1/32–1/16in) lip where the flap surfaces were proud of the wing trailing edge in places! The wing servos were functional but had some slop. Again, more duct tape was present: holding the servo covers in place and hiding yet more old yellow tape underneath. Lastly, the covering film had some span-wise ripples and bubbles in a few places. All in all, it needed a bit of work, but nothing too major. I suppose it *could* have flown as is, but it would not have been pretty!





Duct tape, SATA holes and lumpy hinges. Click on any image for more detail.

Lurking under the servo covers were a pair of full size Futaba *S3003* and Hitec *HS-81*. These were replaced with four *HS-82mg* that I had on the shelf. All four were easily removed by hand: the Futaba were held in by silicon and the Hitech with a rubbery glue that put up a little more effort but not much.



Quality servos, poorly fitted... with silicon.

Yellow tape residue and any left over adhesive was easily removed with some brake cleaner and clean rags. WD40 also works but take a little longer.



Old, yellow tape and rippled covering film.



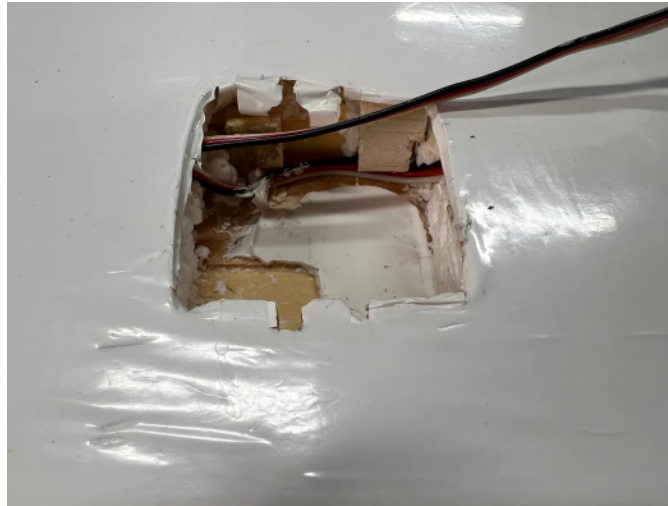

Tape residue before and after.

Once the residue was removed, the ripples were removed by running the covering iron over and pressing down with a clean, soft cloth. Next task: re-hinge the surfaces. This was done using *Tesa* transparent tape used to repair green house glass (link in *Resources*), attaching the inner hinge first then the top surface. The aileron and flap panels were also re-covered in vinyl as the film was a bit too far gone in places.





Smooth hinges, recovered surfaces.

With the hinges done, attention switched to the servos and wiring. The flap servo rebates were backfilled as needed to take the smaller replacement HS-82mg servos, the aileron servos are a direct replacement, so no need for changes there. Linkages were checked over and found in fair condition, no need for changes there, just adjust and lock off with a dribble of CA to limit slop.

The existing wiring had a few solder joints and felt a little stiff, like the case was just 'on the turn' from pliable to brittle so I replaced them. The new servos had their stock length leads which is a pain to hide, so these were cut down and re-terminated. The junctions were secured with heat shrink to ensure they don't come loose and tucked back into the wings.

With the servos re-fitted, using servo tape under and cross weave above, the servo fairings were finally cleaned up and re-fitted.

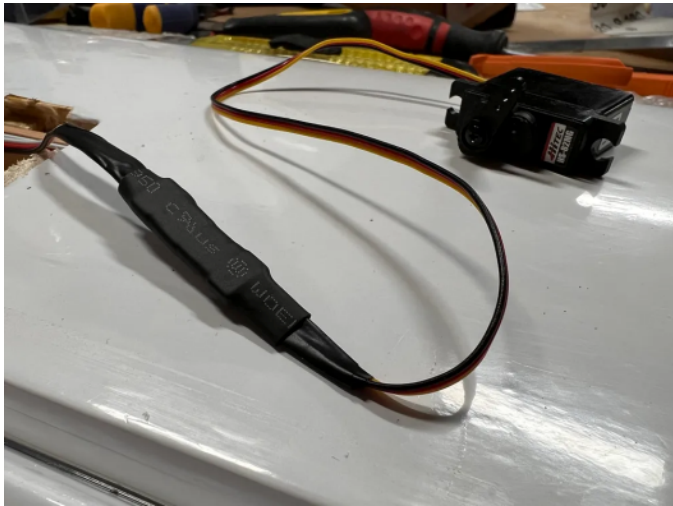
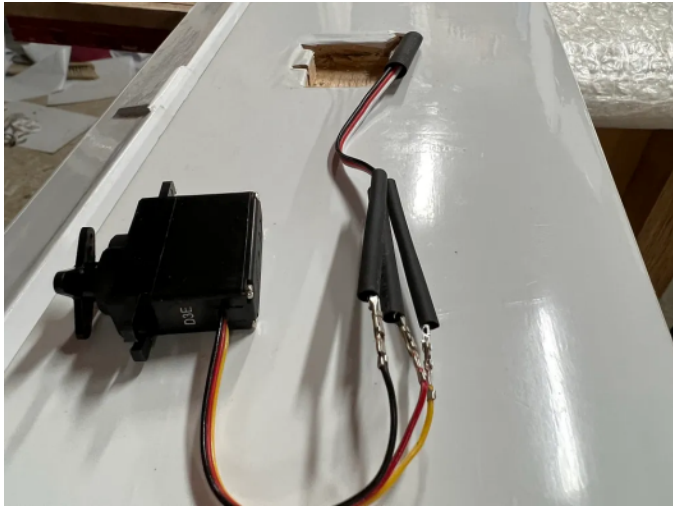

Re-terminated, heat shrink for both servos.





Re-fit the control horns, fit the covers.

The final step was to refresh the graphics a little. The old stickers were removed and the residue cleaned up along with the rest of the wing. Fresh graphics were cut on the *Cricut 3* vinyl cutter and applied to the flaps. A SimProp logo was re-made and applied to the right wing tip.



Remade retro-style graphics.

That's it. Five minutes and it's flying again. Here's the proof:

Resources

- [SATS](#) – “Simprop Artificial Turbulence System ... serves to increase the performance of the model by positively influencing the flow on the upper side of the wing...”
- [Turbulators](#) – “often used to eliminate the separation bubble, and the additional form drag it causes...”
- [Tesa](#) transparent tape. – “First introduced in the 1930s, tesafilm® laid the foundation for a richly successful company history that continues to this date...”
- [Cricut 3](#) – “Cutting machines designed for home crafters. The machines are used for cutting paper, felt, vinyl, fabric...” (Wikipedia)

All images by the author. Read the [next article](#) in this issue, return to the [previous article](#) in this issue or go to the [table of contents](#). A PDF version of this article, or the entire issue, is available [upon request](#).

Stamps That Tell a Story



Centre: "Octave Chanute, 1832–1910, half-length portrait, seated, facing right." (credit: Chanute Papers, Library of Congress). Periphery: Notes about the postage stamps in this montage can be found below.

Philatelic tributes to aviation pioneer Octave Chanute.

The United States Postal Service issued a set of two international airmail stamps (above, right) to honour Octave Chanute, French born, American civil engineer, inventor, aviation pioneer and aeronautical historian.

This is the second issue in the Pioneer Aviation Series honouring American aviation pioneers and significant aviation developments. The series began in 1978 when two stamps were issued in tribute to the Wright brothers, seventy-five years after their 1903 flight.

This stamp series shows a new and different approach to the normal printing of these small pieces of paper. The evolution in the invention of the aeroplane is colourful and broad, so this subject was ideal for

the offset/intaglio process which combines engraved lines with offset colours.

Ken Dallison, a designer and artist from Long Beach Island, New York, USA and Ontario, Canada, is well-known for his mastery of the 'line-and-wash' technique, but he also skilfully combines faces and machinery.

He is very interested in the ingenuity of man. In his biography Dallison writes, "I always attempt to fill my drawings with characters in the same way a director would cast a movie, fulfilling the need to create a good design and tell a story."

This skill was needed for the Pioneer Aviation series. Looking at the two Chanute stamps, Dallison succeeded to capture all the important aspects of the two months' of glider flying experiments along the southern shore of Lake Michigan, near what is now Gary, Indiana.

Dallison used figures from Chanute's talk with lantern slides *Gliding Experiments*, which was given to the Western Society of Engineers in Chicago in October 1897.

Octave Chanute and his team arrived at Miller Beach in June 1896 to start a series of gliding flight experiments. More than 700 successful flights provided him with significant aerodynamic data.

Afterward he willingly shared this data enabling the Wright brothers and other pioneers to develop more advanced flying machines. In fact Wilbur and Orville acknowledged Chanute's key role as a mentor, saying that his research and continual inspiration paved the way for their success.

Chanute corresponded with them for many years and even visited their camp at Kitty Hawk during their flight experiments.

Chanute's biplane glider design of 1896 proved to be a key step on the road to the invention of the aeroplane.

For a few years it was the most successful heavier-than-air flying machine in the world, making long gliding flights and then sustained flight became a reality.

At that time Chanute's pilots, William Avery and Augustus Moore Herring, had the distinction of being the only pilots in the world to have flown 'heavier-than-air' machines to these heights and to have achieved the longest distances.



The National Soaring Museum dedicated its eighth Landmark of Soaring plaque in 1996, celebrating the 100th anniversary of these experimental flights at Miller Beach in Gary, Indiana.

Chanute was 64 years-old in 1896 when the most important experiments were done. He posed with each of the aircraft for picture taking, but did not attempt to fly. Unfortunately most of the photos were taken the following year. While we know the bulk of the test flights were by Avery and Herring, Charles Chanute, Octave's oldest son, and several amateurs including newspaper reporters, were also allowed to fly. The pilot in the photographs below was probably Mr Herring, as Octave always called him.

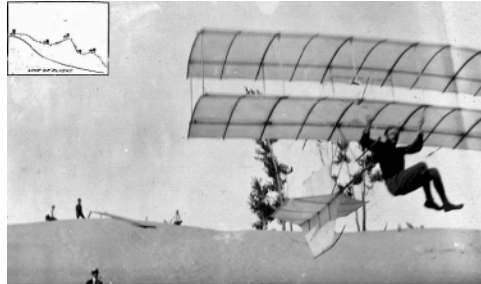
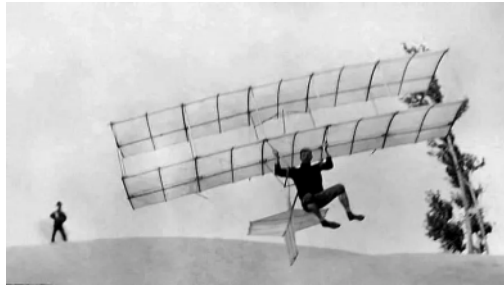

Left: Struck by a side gust. Both these photographs formed part of the illustrations from the talk given around that time by Octave and were used for the first stamp. | Centre: Tobogganing on the air in 1897. Note the many visitors who came to help and try the new sport as well. | Right: The 1897 biplane glider, just sailing (possibly 'ridge soaring') along. (credit: Chanute Papers, Library of Congress)

The longest flight with the 1896 design was recorded as 359ft and lasting 14 seconds.

A cleaned-up and sharpened image of the "sixth form multiple-wing machine," the multiplane *Katydid* is used in the second stamp.

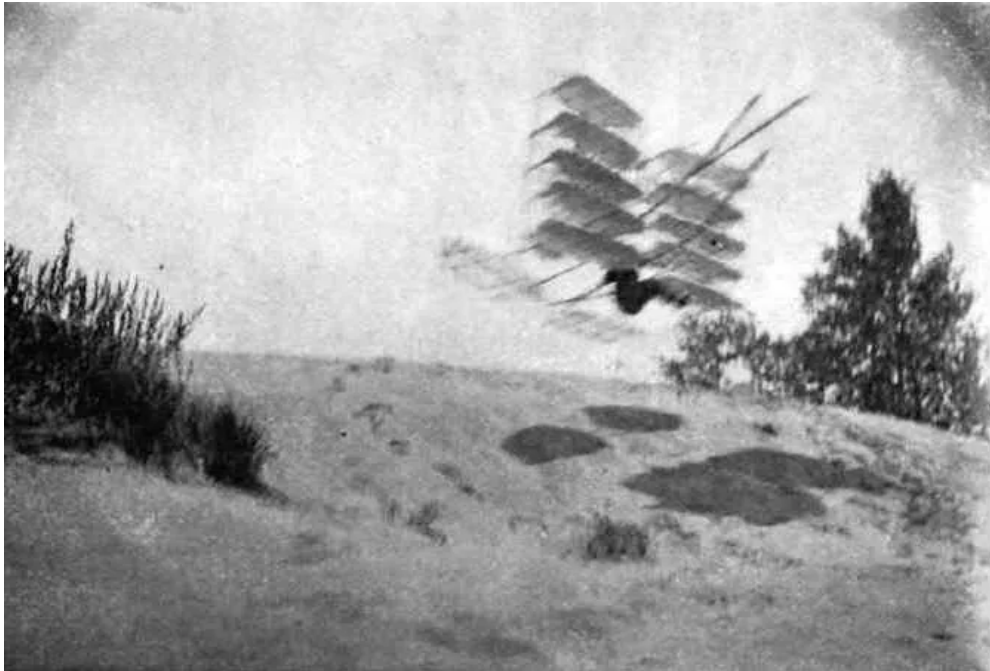

The Katydid multiplane. (credit: Chanute Papers, Library of Congress)

The wing arrangement of this soaring machine was re-rigged six times. Each new experiment was preceded by releasing bits of feather-down in front of the machine and watching the path of air currents sweeping past the wings.

Each wing was marked and each change of rigging recorded. The most successful wing variation used five sets of wings in the front and one as a tail. In a northerly wind, the longest glides in this 37lb machine were 78ft (Avery) and 83ft (Herring). Flight durations weren't recorded.

Much philatelic background information for this article came from a long-time friend, Donald M. McDowell who, at the time these stamps were proposed, designed and issued, was Manager of the Stamp Development Branch, United States Postal Service. Don is a glider pilot and was a co-owner of a Fauvel flying wing.

I also thought it would be of interest to show the other postage stamps issued world-wide to honour Chanute and to acknowledge his contributions in the evolution of the invention of the aeroplane (see key image above the title):

- **Republique Gabonaise** The history of aviation was shown by the Gabon Post Office on six stamps in 1973. The 3 franc issue shows a variation of the Chanute-type biplane. The photo was taken about 1907 and the pilot was a member of the Long Island (New York) Aero Club.
- **Republic of Maldives** The Post Office of the Republic of Maldives shows the 1896 biplane in a very colourful way. It was part of a set issued in conjunction with the 75th anniversary of powered flight in 1976.
- **Federated States of Micronesia** issued several souvenir sheets in 1994 to honour the development in aviation. The 29 cent stamp shows Chanute and a stylised 1897 biplane glider.
- **Uganda** William R. Hanson designed the Chanute stamp for Uganda Post. He combined two images, the sand dunes from a picture of the 1896 experiments with the 1897 biplane, both from Chanute's publications. This made a nice looking postage stamp.

A 2023 Postscript

My article back in 2002 must have struck a chord with me: all these years later I am just wrapping up a full-length book on the subject – *Flight Not Improbable: Octave Chanute and the Worldwide Race Toward Flight*. You can find the link immediately below. It was invaluable to have the luxury of a complete volume on this vitally important – and yet lesser known – figure in aviation history. I have promised the New RCSD an advance copy, and a review of the book will appear in these pages later this year.

©2002, 2023

Resources

- [*Flight Not Improbable: Octave Chanute and the Worldwide Race Toward Flight*](#) by Simine Short to be published by Springer in April of 2023. – “This book is a must-read for all those interested in the evolution of airplanes. Its protagonist, Octave Chanute, is best

known for his scientific and collaborative approach to the engineering problems...” This link also will also enable you to pre-order the book.

- [*Gliding Experiments: An Address by Octave Chanute*](#) – Chanute’s talk with lantern slides was delivered to the Western Society of Engineers in Chicago in October 1897. This talk was published in their journal and later reprinted in other publications. With the permission of the WSE it was transcribed for the web and can be found on Steve Spicer’s website with this link.
- [*Flights before the Wrights*](#) – It is beyond the scope of this article series to give detailed background information on Chanute, the versatile civil engineer. However, if you’re looking for additional insight on this subject take a look at the on-line exhibit sponsored by the John Crerar Science Library, University of Chicago.
- [*To Fly is Everything*](#) – If the invention of the aeroplane and other aviation pioneers is of interest to you, Gary Bradshaw’s website is worth a visit.
- [*A Dream of Wings, Americans and the Aeroplane*](#) by Tom D. Crouch and published by W. W. Norton & Company in 1981. – We are providing a link to just one source of this book (AbeBooks) as an example. Also, check out your local used book store – they may have one as well.
- [*Stamps That Tell a Story: The Series*](#) – Catch up on your missing instalments of this excellent and informative series of articles presented previously in the New RCSD and of which this article is the most recent part.

This basic article first appeared in the September, 2002 issue of Gliding magazine. Simine Short is an aviation researcher and historian. She has written more than 150 articles on the history of motorless flight and is published in several countries around the world as well as the United States. She is also the editor of the Bungee Cord, the quarterly publication of the Vintage Sailplane Association.

Read the [next article](#) in this issue, return to the [previous article](#) in this issue or go to the [table of contents](#). A PDF version of this article, or the entire issue, is available [upon request](#).

Glider Patents

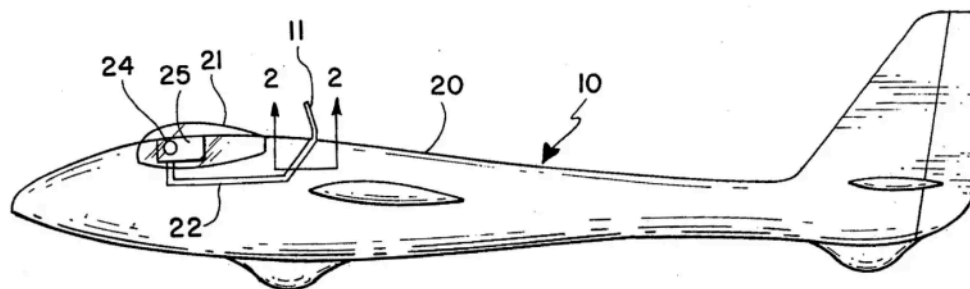

FIG. 1

US 4061028 A: Aircraft Total Energy Sensor

This is the eighth in our series of glider-related selections from the files of the US Patent and Trademark Office (see Resources, below). They are presented purely for the interest and entertainment of our readers. They are not edited in any way, other than to intersperse the drawings throughout the text. Disclaimers: a) Inclusion of a given patent in this series does not constitute an expression of any opinion about the patent itself. b) This document has no legal standing whatsoever; for that, please refer to the original document on the USPTO website. — Ed.

[54] AIRCRAFT TOTAL ENERGY SENSOR

[76] Inventor: **Oran W. Nicks**, 425 Elizabeth Lake Drive, Hampton, Va. 23669

[21] Appl. No.: **772,166**

[22] Filed: **Feb. 25, 1977**

[51] Int. Cl.² **G01C 21/00**

[52] U.S. Cl. **73/179**

[58] Field of Search **73/178 R, 182, 212, 73/179**

FOREIGN PATENT DOCUMENTS

530,260 7/1954 Belgium 73/182

Primary Examiner—Jerry W. Myracle

Attorney, Agent, or Firm—Wallace J. Nelson; Howard J. Osborn; John R. Manning

[56] References Cited**U.S. PATENT DOCUMENTS**

2,923,152 2/1960 Mabry, Jr. et al. 73/179
3,748,900 7/1973 Lindquist 73/178 R

Abstract

An inexpensive total energy sensor utilizing the principles of laminar flow separation around a small cylinder having the desired relationship between static and dynamic pressures for use with sensitive rate of climb instruments for maximum utilization of external pressures by aircraft, in general, and sailplanes in particular.

Origin of the Disclosure

The invention described herein was made by an employee of the United States Government and may be manufactured and used by or for the Government for governmental purposes without the payment of any royalties thereon or therefor.

Background of the Invention

[0002] A sailplane owes its performance to the utilization of energy supplied from external sources. Sensitive rate of climb instruments or variometers connected to static pressure sources are commonly used to indicate rising or sinking of the sailplane.

[0003] The ability of a sailplane to remain aloft for long periods of time, or to cover significant cross-country distances, is dependent upon its effective use of energy supplied by external sources. For this

reason, clear and accurate information concerning the total energy situation and its rate of change are extremely significant to successful soaring. While there are many factors involved in a rigorous treatment of total energy, it is possible for a pilot to interpret his total energy situation with simple modifications to a variometer system. Several methods have previously been used to provide dynamic pressure compensation for rate of climb when zooming or diving, so that the variometer indicates rate of change in total energy instead of rate of change in potential energy. The most widely used compensators have been of two types: diaphragm-volume systems and venturi systems. However, these systems have not proved adequate in continuous flight to give an immediate reading to the pilot of a sailplane of the total energy available, and of rates of change in total energy.

[0004] The total energy of a sailplane at a given time is the sum of its potential and kinetic energies. A pilot customarily determines his total energy situation by a glance at the altimeter and the air speed indicator. In addition to sensing indications of the absolute value of total energy, it is important to “energy management” that the pilot also be able to sense the rate of change in total energy at all times.

[0005] The rate of change in total energy is primarily affected by the drag of the sailplane which is constantly reducing the useful energy, and the air mass energy effects on the sailplane. The drag is dependent on the aerodynamic characteristics of the sailplane, its velocity, altitude, and the load factor. There is little a pilot can do about the aerodynamic characteristics of his sailplane in flight; however, he can control the velocity and the load factor affected by maneuvers. The air mass will be producing sink, climb, or velocity increments to the sailplane which are dependent on its characteristics and the pilot’s skill in positioning the sailplane with respect to local air currents.

[0006] In summary, the useful total energy from a pilot’s viewpoint may be thought of as the instantaneous total energy associated with

his given altitude and velocity, less the energy being dissipated by the drag of the sailplane moving along its flightpath, plus the energy being added to the sailplane by the air mass.

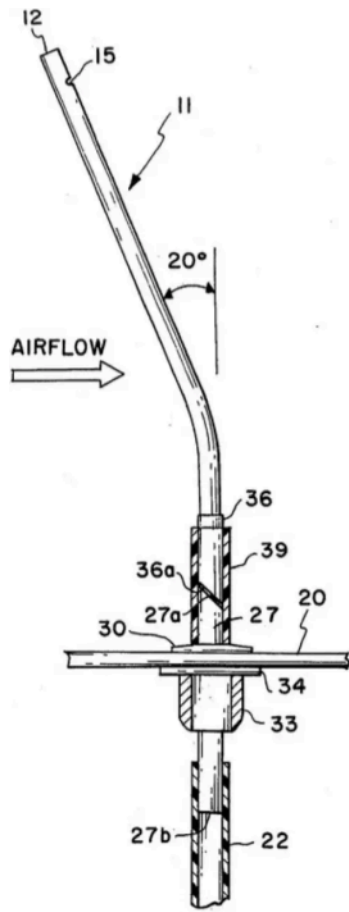

FIG. 2

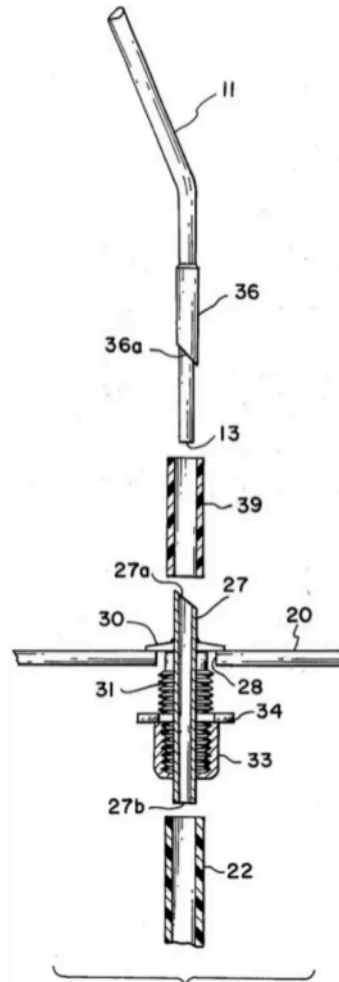

FIG. 3

Prior Art

[0008] Several forms of variometers exist which give accurate rate of climb information. Most of these instruments work on a principle of pressure drop across an orifice or mass flow measurements to and from a reference volume. When connected to a static pressure source, they offer a good indication of rate of change in altitude or rate of potential energy change. If an altitude change occurs at a constant velocity, this reading also represents the rate of change in total energy.

[0009] If the same variometer could be connected to a pressure source which not only varies with the static pressure, but also inversely with the dynamic pressure, it would be possible to use the same instrument for indicating rates of change in total energy.

[0010] Several forms of total energy sensors have been previously developed. In 1940, Kantrowitz described the principles of such a technique. The Irving venturi was a well known approach to this matter and more recently, the Althaus venturi has been widely used. Along with these venturi techniques, many diaphragm systems have been successfully used, one of the most recent being the Schuemann compensator. A recent probe compensator, known as the Braunschweig tube, uses similar principles to those applied in the present invention. However, these prior art devices are relatively expensive, difficult to make, and extremely sensitive to manufacturing tolerances.

[0011] It is therefore an object of the present invention to provide an inexpensive, easy to construct, sensitive aircraft sensor to detect and provide a signal that will indicate rates of change in total energy during aircraft flight.

[0012] It is a further object of the present invention to provide an inexpensive total energy sensor for use with an aircraft.

[0013] It is another object of the present invention to provide a sensitive total energy sensor to facilitate sailplane flight.

[0014] A further object of the present invention is to provide a sensor probe that utilizes a single pressure that varies in proportion to the total energy rate of change of an attached aircraft.

[0015] An additional object of the present invention is to provide an aircraft sensor that detects pressure at a single orifice that is a proper combination of the total and static pressures to give an indication of changes in total energy available to the aircraft.

[0016] Another object of the present invention is to provide a total energy sensor probe that exhibits good compensation over a wide speed and altitude range, is relatively insensitive to flow direction, is easily constructed and produces relatively low drag in use.

Brief Summary of the Invention

[0018] According to the present invention the foregoing and other objects are attained by providing a simple total energy sensor which consists of a small cylinder mounted on an aircraft and angularly inclined forward in the direction of aircraft flight. The cylinder is provided with a single orifice in the aft facing direction at a specific location from the closed cylinder end so that air pressure detected by the orifice will be a proper combination of the total and static pressures and proportional to changes in the total energy of the aircraft. The sensor is in fluid connection with a sensitive rate of climb instrument or variometer and thus provides an instantaneous response to changes in useful total energy for the pilot of the aircraft. This instantaneous indication of changes in useful total energy serves to assist in the piloting of aircraft, in general, and for sailplanes in particular.

(0019) In still air, a sailplane flying at high speeds could exchange most of its kinetic energy for potential energy by zooming. If the sailplane had no drag, the energy exchange would be complete, and a perfect total energy instrument would indicate no change in total energy for such a transfer. Thus, a sensitive variometer could be converted to function as a total energy instrument if the ambient static pressure source were replaced by a pressure source appropriately combining pressures related to the aircraft altitude and velocity. For the imaginary sailplane with no drag, a perfect total energy pressure source would simply provide constant pressure to the instrument throughout the zoom, with the decreasing pressure due to increase in altitude being exactly compensated by a pressure increase inversely proportional to the change in the square of the velocity.

[0020] It is customary to refer to pressures in a non-dimensional form called pressure coefficients, defined by

$$[0021] C_{plocal} = (P_{local} - P_{ambient} / q)$$

[0022] wherein:

[0023] C_{plocal} = Local Pressure Coefficient

[0024] P_{local} = local or sensor pressure source

[0025] $P_{ambient}$ = static pressure

[0026] q = dynamic pressure

[0027] Since P_{local} for a total energy sensor should use the difference of the ambient and dynamic pressures, the required pressure coefficient

[0028] $C_p = 1.0$, i.e.,

[0029] for $P_{sensor} = P_{ambient} - q$

[0030] $C_{psensor} = (P_a - q) - P_a / q = - 1.0$

[0031] for the actual case of a sailplane with drag gliding in still air, the variometer sink rate reading with such a source would simply be the sailplane polar value associated with the speed being flown. Thus, the use of a variometer with simple total energy compensation depends on a pilot knowing his polar relationships so that he can easily judge whether rising or sinking air is modifying his sink rate for the known flight speed. This is commonly done by accomplished pilots. It is also possible through recent developments of "netto" variometers, which factor the sailplane polar into the variometer reading, to obtain a direct indication of up and down movements of the air regardless of how the sailplane drag is varying. It is also necessary to use some form of total energy compensation with netto variometers however, and the probe of the present invention is applicable to either form of total energy compensation.

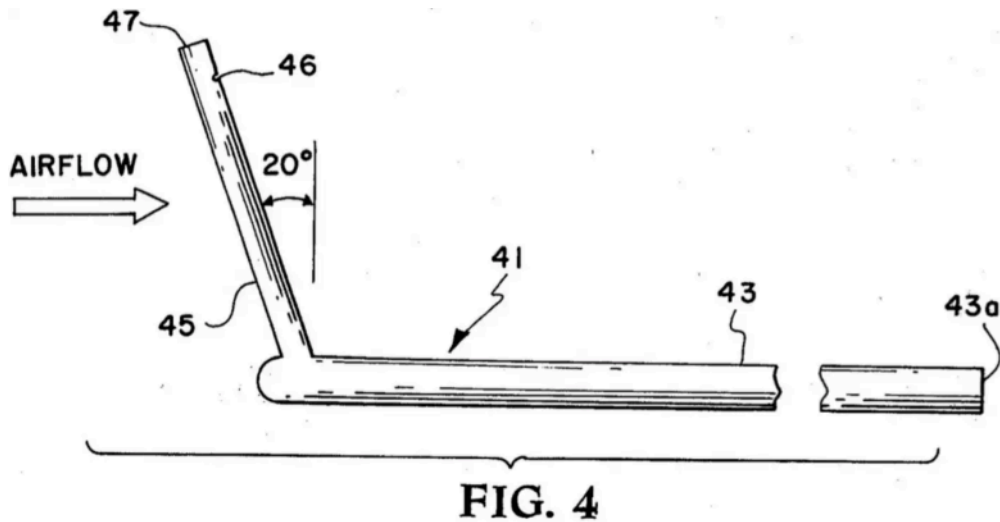

Detailed Description

A more complete appreciation of the invention and many of the attendant advantages thereof will be readily apparent as the same becomes better understood by reference to the following detailed description when considered in connection with the accompanying drawings wherein:

FIG. 1 is a schematic representation of a sailplane with the total energy sensor of the present invention;

FIG. 2 is an enlarged part section view taken along line 2-2 of FIG. 1 and showing details of the total energy sensor probe;

FIG. 3 is an exploded view similar to FIG. 2 and showing the individual parts of the assembly;

FIG. 4 is a view of a modification of a total energy sensor probe according to the present invention; and

FIG. 5 is a schematic view of one mounting location for the probe shown in FIG. 4.

[0001] Referring now to the drawings and more particularly to FIG. 1, there is shown an exemplary sailplane generally designated by reference numeral 10 equipped with the total energy sensor according to the present invention. The total energy sensor probe in the

illustrated embodiment is designated by reference numeral **11** and is disposed on fuselage **20** of said plane **10** just aft of canopy **21**. Sensor probe **11** is in fluid communication via conduit **22** with a sensitive variometer or rate of climb instrument **24**. Variometer **24** is positioned on instrument panel **25** within the sailplane and in position to be visible to the pilot.

[0002] Referring now more particularly to FIGS. **2** and **3**, it is readily seen that probe **11** is of cylindrical or tubular configuration and has a closed end **12** and an open end **13**. Closed end **12** of probe **11** is inclined 20° forward relative to the direction of flight of aircraft **10** as noted by the arrow labeled "airflow" while open end portion **13** is perpendicularly disposed relative to fuselage **20**. An orifice **15** is formed in the aft surface of tubular probe **11** a specific distance from the closed end **12** thereof as will be further explained hereinafter.

[0003] A mounting tube **27** extends through an aperture **28** formed in fuselage **20** of aircraft **10**. Mounting tube **27** is provided with a washer or fairing **30** soldered or otherwise sealed to the exterior thereof and adapted to sealingly engage aperture **28** at the exterior of fuselage skin **20**. An exteriorly threaded tubular fitting **31** is soldered or otherwise sealingly secured to mounting tube **27** adjacent washer **30** and extending to the interior of fuselage **20**. A threaded nut **33** and a washer **34** are positioned on tubular fitting **31** so as to firmly secure mounting tube **27** fixed relative to fuselage **20**. The end portions of mounting tube **27** extend through the fuselage skin **20** so as to present an exposed end **27a** on the exterior of skin **20** with the other end **27b** of tube **27** being disposed within fuselage **20**. Exposed end **27a** of mounting tube **27** is diagonally or bias cut with the diagonal portion sloping rearward relative to the longitudinal axis or direction of flight for aircraft **10**, as will be further explained hereinafter.

[0004] The interior diameter of mounting tube **27** and the outside diameter of probe **11** are essentially equal so as to provide a tight sliding fit therebetween when probe **11** is secured to the aircraft fuselage **20** (FIG. 2).

[0005] An external sleeve **36** is positioned around a portion of probe **11** and secured spaced from open end **13** thereof so as to limit the length of probe **11** that extends into mounting tube **27**. Sleeve **36** is soldered or otherwise conventionally secured to probe **11** to prevent relative sliding movement therebetween and to insure the same orientation of probe **11** relative to the axis of sailplane **10**. Mounting tube **27** and sleeve **36** are of essentially identical internal and external dimensions and a diagonal or bias end **36a** is provided on sleeve **36** to mate with diagonal end face **27a** of tube **27** when probe **11** is inserted therein. The matching surfaces **27a** and **36a** provide for mounting adjustment to allow probe **11** to always maintain a forward slope relative to the longitudinal axis or direction of flight for aircraft **10**. A tubular connector **39** is disposed around the mating portions of **27a** and **36a** of sleeve **36** and mounting tube **27** to provide a hermetic seal between these parts. Connector **39** also serves to keep probe **11** tightly engaged with mounting tube **27** and this, along with the diagonal mating faces **27a** and **36a**, prevents probe **11** from rotating during aircraft flight.

[0006] As readily seen in FIGS. 2 and 3, probe **11** is easily installed and may be removed when the aircraft is in storage or non-flight status for protection thereof. When removed, a suitable closure, such as a length of sealed tubing, or the like, may be used to seal end **13** of probe **11** and end **27a** of mounting tube **27** to insure that no trash enters the parts.

[0007] Referring now to FIG. 4, an alternate embodiment of the total pressure sensor probe is shown and designated generally by reference numeral **41**. Probe **41** includes an elongated tubular segment **43** having an open end **43a**. Elongated segment **41** is disposed parallel with the direction of airflow during operation as represented by the arrow. An integrally attached probe extension **45** of elongated segment **43** and in fluid communication therewith extends into the airflow at the same angular relationship with respect to the vertical as probe **11** described hereinabove. Probe extension **45** is provided with an orifice **46** in the aft surface and spaced a distance

from the closed end **47** thereof. As in the previous embodiment, orifice **46** serves as a pressure source that appropriately combines the pressures related to aircraft altitude and velocity to provide total energy indications to the attached variometer.

[0008] Referring now more particularly to FIG. **5**, one suitable mounting location for the probe shown in FIG. **4** is illustrated. As shown therein the elongated segment **43** of total pressure probe **41** is secured at the open end thereof to the vertical tail **50** of an aircraft in such position as to dispose angular extension **45** into the free stream airflow. Suitable conduit **52**, leading through vertical tail **50**, connects total energy probe **41** to a sensitive variometer on the aircraft instrument panel (not shown) as in the previously described embodiment.

[0009] Although no specific materials have been mentioned for constructing the probe of the present invention, brass, steel, and stainless steel tubing have been used in the examples tested to date. Tube diameters tested in construction the present invention were 3/16 inch 7/32 inch and 1/4 inch. Conventional solder was used to plug the ends **12** and **47** and, in some instances, a small wad of steel wool or brass scraps were inserted into the end prior to soldering to assist in holding the solder in place. After soldering, all tubes tested were filed off normal to the tube and slightly beveled. Holes were drilled in the tubes tested with high-speed drills and deburred. Various size holes from 1/32 inch to 1/8 inch were tested. Various distances of the holes from the closed tube end were tested with all measurements being made from the center of the holes. Various angular settings of the probe relative to the air flow in a wind tunnel were tested. The three-dimensional effects on pressure coefficients that result from having the holes near the end of the tube led to the finding that certain hole locations would give the desired coefficient. It was thus determined that probes having a forward sweep of about **20°** and pressure holes located such that $X/D = 2$ gave the desired pressure coefficient of $C_p = -1.0$ (where X is equal to the distance of

the hole from the tube closed end and D is equal to the tube diameter).

[0010] In the specific embodiments illustrated, probe **11** is normally five to **6** inches in length and is formed of 3/16 inch diameter brass tubing, orifice **15** is 1/16 inch diameter and is formed on the aft surface and 3/8 inch from closed end **12**. In the embodiment of FIG. **4** a twelve inch length of 3/8 inch diameter brass tubing is used for elongated segment **43**. Extension **45** is soldered to segment **43** and is formed of 3/6 inch diameter tubing with orifice **46** being 1/16 inch diameter on the aft surface thereof 3/8 inch from closed end **47**.

[0011] Further details and test results for other size tubing, orifice angular and linear locations and size, and probe angular settings are set forth in NASA TMX-73928 published March 1976. It suffices to say here that for a range of velocities from **40** to at least 150 miles per hour and for altitudes from sea level to at least 20,000 feet, a probe diameter of 3/16 inch is satisfactory. For this diameter, an aft facing orifice 1/16 inch in diameter should be located 3/8 inch from the end of the probe and the probe swept forward 20°. Larger diameter probes tested also provided the desired total energy compensation but they also produce proportionately high drag values than the 3/16 inch diameter tubes.

[0012] The various fittings for probe **11** may be formed from brass or other suitable metal with the exception of the conduit tubing **22** leading from the probe to the variometer and tubular connector **39** (FIGS. **2** and **3**). These members are formed of suitable flexible plastics or the like to insure a leak-proof sealed pressure measurement conduit since the total energy indication is extremely sensitive to leaks. Also, all soldered connections and the soldered end **12** of probe **11** and end **47** of probe **45** must be free from leaks.

[0013] Most flight tests of the present invention have been conducted with a Schweizer 1-26B sailplane and a Ball Electric Variometer Model 101-D. However, some flights have also utilized the Winter and PZL variometers, and a probe according to the present invention has

been substituted for the Althaus probe that is mounted on the forward fin of the Standard Libelle with excellent results.

[0014] The specific location of the total energy probe may be varied but for the Schweizer 1-26B and the Standard Libelle the fin location positioning the probe tip in the free stream air, such that the probe measurement is not affected by the changes in pressure over the wing and body, appear to give slightly better results than other fuselage locations.

[0015] For both embodiments illustrated (FIGS. 2 and 4), smoothly executed zooms during flight testing resulted in a steady change in rate of sink readings between the correct values for speeds at beginning of zooms to the proper sink rates for thermalling speeds. Also, no excessive overshoots in climb or sudden increases in sink rate were exhibited during zooms. Similar results were obtained from pushovers from thermalling speeds to various cruise speeds and during rapid transients with elevator movement, rudder movement, and sideslip. In addition, loops, lazy eights, and others coordinated maneuvers involving changing speed and altitude gave good qualitative checks during transient conditions. Although no flight tests have been conducted to date above 10,000 feet, no variations were noticed nor expected as a result of altitude changes.

[0016] The spectrum of cross country speeds for sailplanes is normally from about 40 miles per hour to 150 miles per hour, and at altitudes from sea level to about 20,000 feet. For this spectrum of speeds and altitudes, ratios of Reynolds number to diameter, R/d , (usually referred to as unit Reynolds number) fall within values of $2.5 \times 10^5/\text{ft}$ and $16 \times 10^5/\text{ft}$. In actual practice, the most important region for compensation ranges between R/d values of $5 \times 10^5/\text{ft}$ to $10 \times 10^5/\text{ft}$. For 3/16-inch diameter sensors, this results in Reynolds numbers ranging from about 8,000 to 16,000.

[0017] The drag for a 3/16 inch diameter probe 5 inches long and having a 20° forward sweep angle on an aircraft having a speed of 100 mph at 5000 feet altitude was computed by standard techniques

to be approximately one-tenth of a pound. It is thus seen that the drag is negligible for sailplanes and most other aircraft, traveling at relative low speeds. However, for jet propelled or other high speed aircraft that would increase the drag, the probe could be conventionally retracted during the high speed flight regime and extended only during the low speed landing approaches. Along these lines, although the invention has been described with specific emphasis on sailplanes, it is equally applicable for other aircraft where total energy availability is desired for optimum flight operations. The pressure signal from a total energy sensor as described herein can be used to provide information on wind shear or airspeed changes due to atmospheric disturbances. When on final approach, reaction to such disturbances in a timely manner can be critical. The simple total energy sensor of the present invention offers a sensitive signal for providing a pilot indications of such occurrences so that corrective actions can be taken quickly and surely. The signal from such a sensor may also be coupled directly with aircraft controls such as the auto throttle or aerodynamic controls to effectt an immediate response to atmospheric conditions which adversely affect the flight path and flight conditions, especially during approach and landing. The integration of static and dynamic pressures by the simple total energy sensor of the present invention is unique in providing sensitive, quick response information for such purposes. Thus, the present invention is particularly useful for pilot analysis of shear and gust loads on aircraft during final landing approach.

[0018] From the foregoing, it is readily seen that the present invention provides a total energy sensor that, when coupled with a good variometer in a leak-free system, provides good total energy rate information to the pilot of an aircraft over a flight range from 40 to at least 150 mph and at altitudes from sea level to at least 20,000 feet. Further, the total energy probe described herein is insensitive to yaw, pitch and roll attitude variations and drag of a typical installation at 100 mph is only about one-tenth of a pound.

[0019] Although the invention has been described relative to specific embodiments thereof, it is not so limited and many modifications and variations thereof will be readily apparent to those skilled in the art in the light of the above teachings. Thus, changes in the materials used, the dimensions given in the specific examples and the mounting locations described may be changed without departing from the spirit or scope of the present invention. It is therefore to be understood that within the scope of the appended claims, the invention may be practiced otherwise than as specifically described herein

FIG. 5

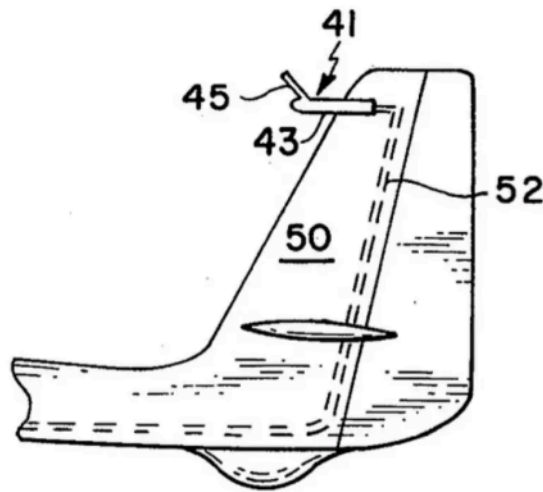

Claims

1. An energy sensor probe for providing a signal representative of changes in useful total energy for an aircraft during flight comprising: ¶ an elongated tubular member positioned on the exterior of the aircraft and having an open end and a closed end, ¶ said closed end of said tubular member being angularly inclined forward relative to the direction of flight of the aircraft and provided with a single orifice formed in the aft portion thereof and spaced from said closed end, ¶ said open end of said tubular member being in fluid connection with a sensitive variometer whereby, during aircraft flight the laminar air flow around said tubular member produces pressures which vary with changes in

aircraft velocity and altitude that are proportional to changes in total energy pressure and these changes being detected by the energy sensor probe and indicated by the variometer.

2. In combination, an aircraft and a variometer provided on the instrument panel thereof to provide readings of the available total energy air pressure available during flight of the aircraft at a given instant, the improvement therewith consisting of: ¶ a total energy pressure probe exteriorly disposed on the aircraft, ¶ said total energy pressure probe being an elongated tubular member having an open end portion and a closed end portion, ¶ the open end portion of said tubular member being secured to the aircraft fuselage so as to be in fluid communication with the variometer and the closed end portion of said tubular member extending into the free airstream about the aircraft, ¶ said closed end portion of said tubular member being provided with a single orifice disposed in the aft cylindrical portion thereof and spaced from the closed end thereof, ¶ whereby, laminar flow around the tubular member produces pressures that vary with changes in aircraft velocity and altitude proportional to changes in total energy and these pressure changes are transmitted through the total energy pressure probe to the aircraft variometer.
3. The combination of claim 2 wherein said open end portion of said tubular member is disposed perpendicular to the aircraft fuselage and said closed end portion of said tubular member is inclined angularly toward the direction of flight of the aircraft.
4. The combination of claim 3 wherein said closed end portion of said tubular member is inclined 20° angularly forward relative to said open end portion of said tubular member.
5. The combination of claim 2 wherein the single orifice disposed in the aft cylindrical portion of said tubular member is positioned a distance from said closed end thereof such that $X/D = 2$ where X is equal to the distance of the orifice center from the closed tubular end and D is equal to the diameter of said tubular member.
6. The combination of claim 2 including means for releasably securing said tubular member to the aircraft fuselage and serving

to maintain the same orientation of said tubular member relative to the longitudinal axis of the aircraft.

7. The combination of claim 2 including a mounting tube extending through the aircraft fuselage for releasably securing said tubular member to the aircraft fuselage, said mounting tube having an internal diameter substantially equal to the external diameter of said tubular member and adapted to slidably receive the open end and a length of said tubular member.
8. The combination of claim 7 wherein said mounting tube is provided with a diagonal end face at the end thereof extending exterior of the aircraft fuselage, a sleeve member rigidly secured to said tubular member a distance spaced from the open end thereof, said sleeve member having an interior diameter substantially equal to the external diameter of said tubular member and provided with a diagonal end face adapted to abut against and mate with the diagonal end face of said mounting tube when said tubular member is slidably positioned therein to thereby limit the distance said tubular member extends into said mounting tube.
9. The combination of claim 8 and further including a flexible tubular connector slidably positioned over said sleeve member and said mounting tube at the mating faces thereof when said tubular member is positioned within said mounting tube to thereby provide a hermetic seal between these parts.
10. The combination of claim 9 including a flexible tubular conduit connecting said mounting tube to the aircraft variometer.
11. The combination of claim 7 including means for fixedly securing said mounting tube to the aircraft fuselage, said means including a fairing washer disposed about said mounting tube and abutting against the exterior of the aircraft fuselage, said fairing washer being secured to said mounting tube, an exteriorly threaded fitting slidably disposed about the length of said mounting tube extending into the interior of the aircraft fuselage, said fitting being bonded to said fairing washer, an internally threaded nut threadingly secured to said threaded fitting, and a washer disposed between said threaded nut and the interior of the aircraft fuselage

and adapted to tightly engage the interior of the aircraft fuselage when said threaded nut is tightened to thereby secure said mounting tube to the fuselage.

Further Reading

These photographs and articles were not part of the original patent filing and are provided here solely for those readers interested in additional background reading regarding the patent above.



Left: Oran W. Nicks at Texas A&M University Department of Aerospace Engineering. (credit: Texas A&M University) | Right: "Visit to the Lewis Research Center, now known as the Glenn Research Center, by Dr. Wernher von Braun,

Deputy Associate Administrator, and Mr. Oran W. Nicks, Acting Associate Administrator.” (credit: NASA)

- [*A Simple Total Energy Sensor*](#) by Oran W. Nicks as it appeared in *Technical Soaring* Vol. IV, №3. — “This research study of simple technique for total energy compensation having the primary requirement of good compensation with a low cost, easy to make sensor...”
- [*Further Developments in Simple Total Energy Sensors*](#) by Oran W. Nicks, Langley Research Center — “In 1976, research results were published on a simple total energy probe concept using principles of laminar flow around a cylinder ... [a]dditional tests have been conducted to further support earlier findings and options for probes made of a single bent-up tube...”
- [*Oran W. Nicks*](#)’ biography from the Texas A&M University Department of Aerospace Engineering website. — “He organized and directed a Space Research Center involving over 100 faculty and students from 1985 to 1991, developed and led interdisciplinary teams doing research on regenerative life support systems, on space power, and on space transportation systems...”

Resources

- [*US Patent and Trademark Office*](#) (USPTO) — The USPTO provides an outstanding search engine which enables digging through (seemingly) every patent in their archive. Proceed with caution — you could easily spend **days** of your time digging through their utterly fascinating files.
- [*US 4061028 A*](#) — A PDF of the original patent as downloaded from the USPTO website, on which this article is based.
- [*Glider Patents*](#) in the New RC Soaring Digest. — The complete compendium of articles appearing in this series.

Thanks to Editorial Assistant

for her invaluable assistance in preparing this article. Read the [next article](#) in this issue, return to the [previous article](#) in this issue or go to

the [table of contents](#). A PDF version of this article, or the entire issue, is available [upon request](#).

The Trailing Edge



Leo Horta's dog Jade and pilot Paulo Couto are making the most of a lazy day's end, each in their own way. They were captured at Parque Estadual da Serra do Rola Moça near Belo Horizonte, Brasil on January 10, 2023. Relevant links in Resources below. (credit: Leo Horta)

Life according to Jerry Seinfeld.

We had to laugh when we went over The Ed's *In The Air* tome for this month. As if by magic he — finally! — managed to weave a quote from Jerry Seinfeld into his editorial, or rather a line from the *Seinfeld* TV series, which is almost the same thing according to him.

Part of why it made us laugh is that not a day goes by that The Ed doesn't make multiple references to the show to bring to life virtually any point he is trying to make. Actually, he doesn't even have to be trying to make a point — he'll just launch into fits of laughter triggered by something he sees or hears which in turns triggers a memory of a particular line in a particular episode which is his cue to recite it chapter and verse. This is a skill undoubtedly honed by his re-watching the 180 *Seinfeld* episodes countless times.

“Y’know I’ve seen him live, right? Twice!” Yes, we know. It’s only the ten-thousandth time you’ve told us, like it’s the proudest accomplishment of your entire life. “One day, I’m going to write a book about business using examples based entirely on scenes out of *Seinfeld*,” he mutters. Yes we know that too, feigning boredom, offering a yawn and trying to cover up our thinking that’s actually not a half bad idea.

So back to where we started. We laughed not at the twisted logic of his piece so it somehow, sort of supported the *Seinfeld* quote.

No, we laughed because it took until The Ed’s **26th** issue before he did.

New in the RCSD Shop



Featured on this month’s *Cover Photo T-Shirt* is the ethereal image taken by frequent and highly regarded New RCSD contributor Chris Williams. It’s a picture of his new 1/6th-scale Slingsby *Kite*. The gorgeous cabriolet has seemingly punched through the broken layer and is flying above the clouds where it’s always CAVU (clear and visibility unlimited). We’d argue that if you weren’t *told* it was an RC sailplane you’d be hard pressed to know it wasn’t a full-size example, out enjoying a beautiful day over the inimitable English countryside. Available in six colours and a wide variety of sizes. [Order yours today.](#)

All items in the Shop are made especially for you as soon as you place an order, which is why they are fairly priced and it takes us a bit longer to deliver them to you. Making products on demand instead of in bulk helps reduce overproduction and waste. Everybody wins, including Planet Earth.

Thank you for making thoughtful purchasing decisions!

Make Sure You Don't Miss the New Issue

You really don't want to miss the March, 2023 number when it's out — we always have some exciting things in the works. Make sure you connect with us on [Facebook](#), [Instagram](#), [Twitter](#), [LinkedIn](#) and [Post News](#) or simply subscribe to our [Groups.io](#) mailing list. Please share the New RCSD with your friends — we would love to have them as readers, too.

That's it for this month...now get out there and fly!

©2023

Resources

- The key photo for this article was taken by [Leonardo Horta](#) who also has the awesome responsibility of being Jade's guardian. Thanks also to [Rodrigo Lessa](#) for his assistance in making this photo available to RCSD. Please check out their Instagram feeds!

Read the [previous](#) article or go to the [table of contents](#). A PDF version of this article, or the entire issue, is available [upon request](#).